

Uni-Directional Receiving Device

Acceptance Test Plan

Uni-Dir-ATP-I05-040629

ISSUED

Notice

Neither CableLabs nor any member company is responsible to any party for any liability of any nature whatsoever resulting from or arising out of use or reliance upon this document, or any document referenced herein. This document is furnished on an "AS IS" basis and neither CableLabs nor its members provides any representation or warranty, express or implied, regarding the accuracy, completeness, no infringement, or fitness for a particular purpose of this document, or any document referenced herein.

All rights reserved.

This page is intentionally blank.

Document Status Sheet

Document Control Number:	Uni-Dir-ATP-I05-040629			
Reference:	Acceptance Test Plan			
Revision History:	Uni-Dir-ATP-I05-040629			
Date:	June 29, 2004			
Status Code:	Work in Process	Draft	Issued	Closed
Distribution Restrictions:				

Key to Document Status Codes

Work in Process	An incomplete document designed to guide discussion and generate feedback, which may include several alternative requirements for consideration.
Draft	A document in specification format considered largely complete, but lacking review by Members and vendors. Drafts are susceptible to substantial change during the review process.
Issued	A stable document, which has undergone rigorous member and vendor review and is suitable for product design and development, cross-vendor interoperability, and for certification testing.
Closed	A static document, reviewed, tested, validated, and closed to further engineering change requests to the specification through CableLabs.

CableLabs® is a registered trademark of Cable Television Laboratories, Inc.

TABLE OF CONTENTS

1	HOST ACCEPTANCE TEST PROCEDURES.....	6
1.1	Purpose and Scope.....	6
1.2	Definitions.....	6
1.3	Equipment List	9
1.4	Vendor Documentation Package	11
2	CRITICAL TEST COVERAGE OF REQUIREMENTS.....	14
2.1	Test Procedures	15
2.1.1	Host Power Supply Test.....	15
2.1.2	Host-POD Temperature/Average Power Test.....	19
2.1.3	Host PCMCIA Characteristics Test	21
2.1.4	Host Control	26
2.1.5	Host Macrovision Test.....	29
2.1.6	Host Copy Protection and CCI Test	33
2.1.7	UDRD RF Input Return Loss Test.....	44
2.1.8	UDRD Spurious Emissions Test	46
2.1.9	FAT Channel LO Leakage Test	48
2.1.10	Direct Pickup and Radiated Emissions	50
2.2	Second Group Test Procedures	51
2.2.1	Host-POD Interface Visual Test	51
2.2.2	Host Data Channel Multi-Layer Test	53
2.2.3	Initialization Error Detection and Handling	58
2.2.4	Host Conditional Access Resource Test	63
2.2.5	Host System Time Test.....	68
2.2.6	Host MMI Test.....	70
2.2.7	Host Hot Insertion Test	74
2.2.8	Host/POD PCS/OOB Test.....	76
2.2.9	Host Standby Mode Test.....	79
2.2.10	Host Extended Channel Test	81
2.2.11	Virtual Channel Number Processing	84
2.2.12	In band Host Control and Host POD Firmware Upgrade Test (Homing)	89
2.2.13	OOB EAS Tests	97
2.2.14	In-Band PSIP Test	102
2.2.15	In-Band EAS Tests	107
2.2.16	FAT Channel Maximum Individual Carrier Test	109
2.2.17	FAT Channel Adjacent Channel Characteristics Test	110

2.2.18	FAT Channel High signal Test	117
2.2.19	FAT Channel Functional Test	118
2.2.20	FAT Channel HRC/IRC Tuning Test	120
2.2.21	FAT Channel Micro-reflection Test	122
2.2.22	FAT Channel Phase Noise Tolerance	124
2.2.23	FAT Channel AM Hum Modulation Immunity	125
2.2.24	Combined Distortions Test	126
2.2.25	FDC Adjacent Channel Characteristics Test	137
2.2.26	FDC Amplitude Parametric Test	143
2.2.27	FDC tuning range and bit rate test	145
2.2.28	Digital Video Compression Test	148
2.2.29	Digital Closed Caption	153
3	EQUIPMENT CONFIGURATION	156
4	SCIENTIFIC ATLANTA, MOTOROLA & HARMONIC	157
4.1	CORE Interoperability Tests	157

1 HOST ACCEPTANCE TEST PROCEDURES

1.1 Purpose and Scope

The Acceptance Test Plan (ATP) is a compendium of test procedures that shall be used to demonstrate that a Unidirectional Receiving Device complies with certain Host and interface specifications. CableLabs and Consumer Electronic Manufacturers have developed these procedures to facilitate the product development and certification efforts of equipment suppliers.

The ATP techniques contained in this document are not necessarily the only methods for demonstrating compliance, but represent the specific tests that have been jointly developed and accepted by mutual agreement. In the alternative, Equivalent ATP's that produce identical pass/fail results for each of the PICS as are produced under the ATP procedures contained herein may be used in accordance with, and upon execution of, the Agreement Concerning Equivalent ATP's dated February 25, 2004; or in accordance with the rules of the Federal Communications Commission, at such time as they are amended as described in that Agreement. The ATP procedures contained herein shall be used by CableLabs and by any other party seeking to Verify, Self-verify, or otherwise certify that a Unidirectional Receiving Device complies with the relevant specifications. As new testing methods or the use of alternative test equipment or procedures are approved by mutual agreement as providing consistent results, they will be added to this document.

The ATP procedures are “black box” tests; that is, they do not require opening the equipment under test to access special test points or to invoke test modes of operation. There are requirements that cannot be verified by black box techniques and supplier-proprietary procedures are required to test such requirements. These supplier-proprietary test procedures are beyond the scope of the ATP.

This ATP tests compliance with certain PICS requirements. Successful completion of this ATP does not guarantee that a device will operate properly in a commercial environment, interoperate with other devices, or conform to other requirements. Subsequent revisions of this document may contain additional test procedures.

1.2 Definitions

UDRD	Uni-Directional Receiving Device
Low channel	61.25 MHz analog visual carrier, 63 MHz center freq QAM (channel 3)
Mid channel	211.25 MHz analog visual carrier, 213 MHz center freq QAM (channel 13)
High channel	571.25 MHz analog visual carrier, 573 MHz center freq QAM (channel 82)
Default V/A ratio	13 dB Video to Audio carrier ratio for NTSC signals
Default QAM signal levels	-5 dBmV for 256 QAM, -10 dBmV for 64 QAM, 0 dBmV is normal for analog.
Default digital video	HD moving zone plate

Default QPSK signal level -7 dBmV

Note: Individual tests procedures that specify a specific set-up must be followed. In the test procedures where no specific setup is specified the "Default" value/level from above may be used.

Proper reception:

- (1) For analog signals: Means picture and sound with no impairments lower than a rating of 4 on the ITU-R BT.500 scale. ("Perceptible, but not annoying")
- (2) For digital signals: Means picture and sound with no impairments lower than a rating of 4 on the ITU-R BT.500 scale. ("Perceptible, but not annoying")

FDC Noise Power bandwidths

Transmission Rate	Noise BW	Correction Factor
1.544 Mbps	1.00 MHz	60 dB
2.048 Mbps	1.33 MHz	61 dB
3.088 Mbps	2.01 MHz	63 dB

CHANNEL POWER MEASUREMENT

Ensure that the spectrum analyzer has been on for at least 0.5 hrs and is calibrated. Refer to equipment manual for proper calibration procedure.

Configure the analyzer as follows:

Mode	Spectrum Analyzer
Center Frequency	Center of channel under test
Amplitude Units	dBmV
Input Z	75ohms
Ref Level	Positioned to upper 1/10 of display
Span	Wide enough to capture entire signal under test (6 MHz for FAT)
RBW	300 kHz
VBW	30 kHz or less
Video Averaging	ON

Change Marker Mode to display power on a per Hertz basis (dBmV/Hz).

Move the marker to the center of the signal and record the power level as displayed.

Refer to table and obtain the proper bandwidth correction factor for the signal being measured.

The actual power level of the signal is as follows:

Channel Power = Displayed marker level (dBmV/Hz) + correction factor

For FAT QAM channels the correction to be used is 68 dB.

Some tests may have more than one brand of equipment that may be used to complete the test and may be substituted when applicable.

1.3 Equipment List

CEA/Cable JTS ATP Equipment List

Model Number	QTY	Description
HP8561E	1	Spectrum Analyzer
HP89441A	1	VSA
D9476	3	Scientific Atlanta QAM Modulators with ASI ports
Sycard 140A	2	Sycard PCEExtend Cards
Sycard 145	1	Sycard PCEExtend Card
	1	Type I PC Card
	1	Type II PC card
Fluke 54-2	1	Fluke 54-2 Dual input thermometer
	2	80PK-1 bead probe thermocouples
GK-0212-xx	1	Thermo label mini (xx: Temperature is indicated by suffix in the catalogue) thickness is 0.07mm Contact person in Toyorika corp.: Mr. Takeuchi +81-3-3252-3761 **Alternative to 80PK-1 bead probe thermocouples.
DC Electronic load devices	2	Such as Kikusui PLZ153W or equivalent
	1	HPNX hardware/software/laptop (see below for laptop requirements)
Ver. 1.2.2003.12121	1	HPNX Software
Minimum system requirements for HPNX PC (or current)		OS - Windows 2000, XP, or Windows Server 2003 with latest service pack updates CPU - Pentium 4, 1.7Ghz or faster Hard Disk - 1 Gig free disk space for software and stream libraries Video 1024x768, 24 bit color, video controller capable of real time MPEG2 decoding (Newer NVidia or ATI cards will do). RAM 256MB CD - ROM for installation Network (10/100 base T) Ethernet card or built in MPEG@ Software Decoder For local rendering of selected channel program. The decoder needs to be installed for the HPNX to work. Software MPEG2 decoder from the following companies. Nvidia, InterVideo, CyberLink (NOTE: The HPNX will not install if there is not a valid MPEG2 Software Decoder installed on the computer). Sound - a sound card or built in installed for local audio rendering of selected program. Appropriate cabling.
Sycard 410 REV01	1	Sycard Reference Thermal Pod
2465	1	Oscilloscope w/NTSC triggering capability (or VM700 Video Tester)
HP8753D	1	Network Analyzer
HP85039B	1	Type F Calibration Kit for HP8753D

1672G	1	Agilent Logic Analyzer
8960	3	Sencore transport streamers (or one that will play three streams at the same time)
	1	Display Monitor
HP 8657A	1	FM Signal Generator
C6M	1	Jerrold NTSC modulator
HP11759D	1	HP Ghost Simulator
	1	PC for ghost simulator
ZFM 15	1	Passive double balanced mixer (Mini circuits)
7109	2	Noise generators, one with a gating option (Noisecom)
HP8116A	1	HP Pulse Generator
Acterna FireBerd 6000	1	Acterna FireBerd 6000 Communications Analyzer with Lab BNC interface
BCM93133	1	Broadcom QPSK modulator
RF Networks 5450	3	QPSK modulator for each data rate
	1	QAM mod that supports channel 3
	1	NTSC signal source
C6U	1	upconverter (for NTSC)
NC7102	1	Audio noise generator
ZYSW-2-50DR	1	RF Switch Mini-Circuit's
Motorola Headend	1	Motorola one-way development headend with CableCARD's.
Scientific Atlanta Headend	1	Scientific Atlanta one-way development headend with CableCARD.
Harmonic Headend with NDS CAS	1	Harmonic one-way development headend with NDS CableCARD's

Note1: ability to provide cables, adapters, splitters; custom wiring to extender cards is required.

Note2: This JTS Equipment List is subject to changes, additions, or alternatives as mutually agreed by the JTS working group. CableLabs does not endorse such Equipment in any manner.

1.4 Vendor Documentation Package

This ATP requires certain vendor documentation as proof of compliance. The table below summarizes this documentation and maps it to the ATP test section.

<u>ATP Reference</u>	<u>Vendor Supplied Information</u>	<u>PICS Reference</u>	<u>Standard Reference</u>
2.1.3 Host PCMCIA Characteristics Test	Pull-down resistors are used on MCKLO to prevent spurious operation	HPPii.13	ANSI SCTE 28 2004 HOST-POD Interface Standard Section 6.7.5, Step 7
2.1.5 Host Macrovision Test	Proof of Macrovision certification	HACP.2	ANSI SCTE 41 2004 POD Copy Protection System Section 6.1.2 Table 6.1-C
2.2.1 Host-POD Interface Visual Test	The POD connector meets the reliability standards described in Section 7 of PC Card Standard, Volume 3 - Physical Specification	HPPh.6	EIA-679-B (Part B) National Renewable Security Standard Section A.5.4.5
2.2.1 Host-POD Interface Visual Test	The POD connector meets the durability standards described in Section 8.2 (harsh environment) of PC Card Standard, Volume 3 - Physical Specification	HPPh.7	EIA-679-B (Part B) National Renewable Security Standard Section A.5.4.6
2.2.6 Host MMI Test	Manufacture to supply user instruction script and or user Instructions for user navigation within the MMI resource	DapMi.12	SCTE 28 2004 HOST-POD Interface Standard Section 8.3.1
2.1.10 Direct Pickup and Radiated Emissions	The UDRD meets the Direct Pick Up requirements.	HMEch.31	47 CFR 15.118 (c)(3)
2.1.10 Direct Pickup and Radiated Emissions	The UDRD meets radiated emissions	HMEch.7	47 CFR 76.605 (12)
None	For the manufacturer's first Uni-Directional Cable Receiving Device, Manufacturer agrees to participate with cable operators and cable operator vendors in a digital interface plug fest event.	HDST.15	Uni-Dir-PICS-I01-030903 PICS

2.1.2 Host-POD Temperature/Average Power Test	The UDRD meets PICS item Hmech.1 manufacture to provide test overview and test results.	Hmech.1	Uni-Dir-PICS-I01-030903 PICS
2.2.3 Initialization Error Detection and Handling	Vendor software analysis or other proof of compliance.	HPinit.288, HPinit.289, HPinit.290, HPinit.291, HPinit.292, HPinit.293, HPinit.294, HPinit.295	SCTE 28 2004 HOST-POD Interface Standard
2.1.6 Host Copy Protection and CCI Test	Vendor submitted documentation to show compliance that the Host was designed and manufactured in a Manner to effectively frustrate attempts to Discover or reveal secrets.	CertMgt.26	Uni-Dir-PICS-I01-030903 PICS
2.2.15 In-Band EAS Tests	Vendor submitted documentation to show compliance that the UDRD was designed and manufactured in a Manner to silently discard cable_emergency_alert() message in accordance with PICS listed.	HNIEAS.11	Uni-Dir-PICS-I01-030903 PICS
2.2.15 In-Band EAS Tests	Vendor submitted documentation to show compliance that the UDRD was designed and manufactured in a Manner to process multi-lingual alert_text(), and shall choose at most one language for display when text is provided multi-lingually.	HNIEAS.30	Uni-Dir-PICS-I01-030903 PICS
In-Band Channel Support PICS with no ATP coverage.	Vendor submitted documentation that the Uni-Directional Receiving Device SHALL not be adversely affected by the presence or absence of the MPEG descriptors as defined in the PICS items listed in the next column.	HstIBCS.16 HstIBCS.47 HstIBCS.48 HstIBCS.49 HstIBCS.9a HstIBCS.6	Uni-Dir-PICS-I01-030903 PICS
Digital Audio PICS with no ATP	Vendor submitted documentation that a Uni-Directional Receiving Device with audio	HNETdig_aud.5 HNETdig_aud.6 HNETdig_aud.11	Uni-Dir-PICS-I01-030903 PICS

	<p>decoding capabilities SHALL implement HNETdig_aud.5 and HNETdig_aud.6 and not be not be adversely affected by HNETdig_aud.11</p> <p>Note: PICS items listed in the next column.</p>		
--	--	--	--

2 CRITICAL TEST COVERAGE OF REQUIREMENTS

At the end of each procedure in the ATP, there is a table listing the Uni-Directional Receiving Device requirements that are covered by that procedure. In the *Quality* column of that table, each requirement is labeled as having **Direct** coverage or **Indirect** coverage. Direct coverage means that the procedure directly observes that requirement.

In the case of direct coverage, the procedure author may include additional information in the *Quantity* column to characterize the degree to which the item is covered. When 100% coverage is indicated, this means that the procedure has verified the subject requirement in all possible ways. If 50% is indicated, then only half of the possible variations of the subject item were directly observed by the procedure. The procedure author may include comments about the test coverage in the *Comments* column.

Indirect coverage means that the procedure may have relied so significantly on the subject requirement as to have virtually demonstrated compliance. For example, bit and byte order may not have been directly tested. Yet, the procedure would have failed to verify other requirements if bit and byte order were not correct.

Under certain conditions, all of the indirect items are deemed to have been demonstrated as compliant. If these conditions are not satisfied, then the Indirect items are neither deemed compliant nor not compliant on the basis of that procedure. If the author of a procedure does not explicitly define the conditions for passing all of the indirectly covered items, then it is assumed that the criterion is that all directly covered items must pass.

2.1 Test Procedures

2.1.1 Host Power Supply Test

Measures the ability of the Host Power Supply to remain within regulation limits with the peak current load of the POD applied.

Equipment: Host under test, (2) DC Electronic load devices, (Such as Kikusui PLZ153W or equivalent), (1) DC Voltmeter, Sycard PCExtend 140A, and quantity (8) \leq 25cm lengths of 22AWG cables with correct connector types.

Setup: Verify the host power cord is disconnected use \leq 25cm length 22AWG hook up wires for the following connections.

- 1.) Connect the two VCC pins on J1 and J2 of the extender card to the positive terminal of the first electronic load. Connect two of the GND pins of J1 and J2 to the negative terminal of the first electronic load.
- 2.) Connect the VPP1 and VPP2 pins on J1 and J2 of the extender card to the positive terminal of the second electronic load. Connect two of the GND pins of J1 and J2 to the negative terminal of the second electronic load.
Connect the extender card to the Host under test.
- 3.) Set the electronic loads to constant current mode. Set the VCC load to 1.0A and the VPP load to 0.25A. (Consult the electronic load manual for operation detail if necessary.)
Plug in the Host.

Note: Due to power supply design options (regulation may be based on VCC output), it may be necessary to apply a load to VCC for VPP voltage test.

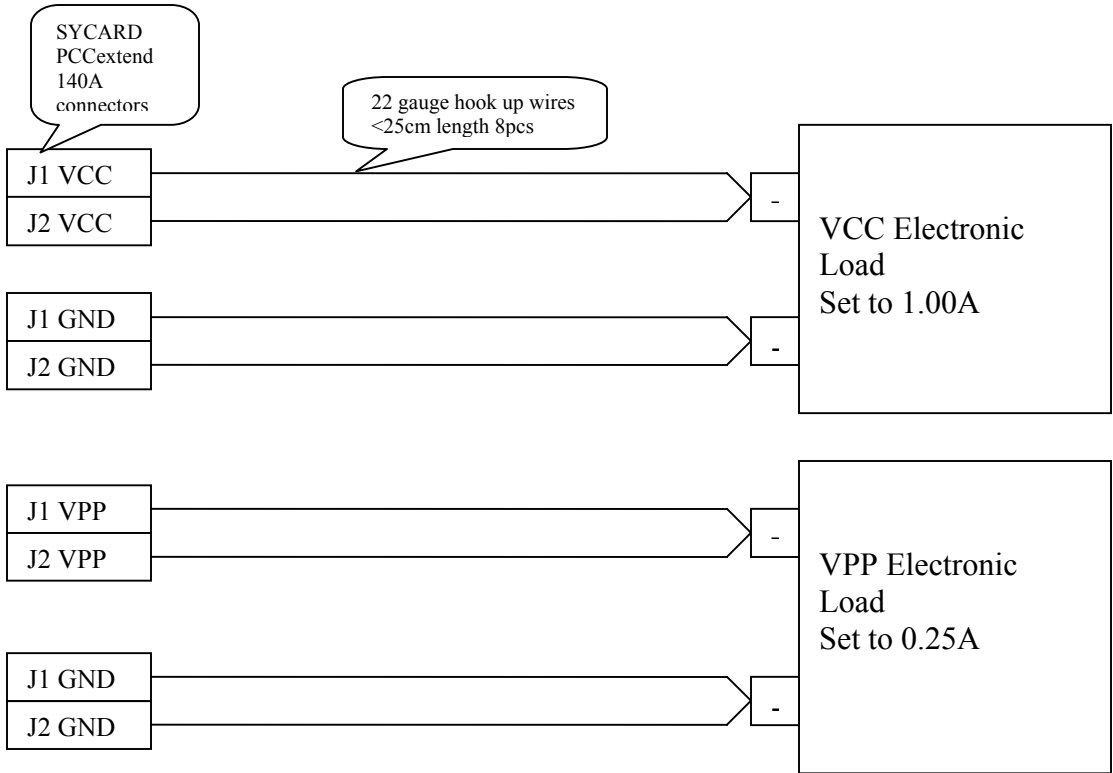

Procedure:

Test 1: Host Peak Current Detection Test Results:

Measurement	Acceptable Result	Result	Comment
Set the VCC electronic load to on. Verify the load is drawing 1.00A with the load meter. If necessary adjust the current setting to draw 1.00A. Measure the voltage between the VCC and GND test points on the extender card with the DC voltmeter. You should measure 3.3V ± 0.3 VDC on the DC voltmeter. Record the results. Set the VCC load to off.	3.3V ± 0.3 VDC		
Set the VPP electronic load to on. Verify the load is drawing 0.25A with the load meter. If necessary adjust the current setting to draw 0.25A. Measure the voltage across C4 on the extender card with the DC voltmeter. The positive terminal of the meter should be connected to the capacitor lead closest to JP1A. You should measure 3.3V ±10% on the DC voltmeter. Record the results. Set the VPP load to off. Optionally (if necessary) apply load to	3.3V ±0.3 VDC		

VCC.			
<p>Disconnect power from the Host and insert the HPNX into the back of the Extender Card. Using the HPNX establish a connection between the HPNX computer and the HPNX itself. Apply power to the Host. Select the CIS Scientific Atlanta table from the CIS pull down window and press the Play button on the POD-Low level test/setup tab to run the initialization script.</p> <p>Set the VPP electronic load to on. Verify the load is drawing 0.25A with the load meter. If necessary adjust the current setting to read 0.25A. Measure the voltage across capacitor C4 on the extender card with the DC voltmeter. The positive terminal of the meter should be connected to the capacitor lead closest to JP1A. You should measure 5.0V ±10% on the DC voltmeter. Record the results. Set the VPP load to off.</p> <p>Optionally (if necessary) apply load to VCC.</p> <p>** NOTE: If CD1, CD2, & VS1 have been grounded to provide card detect signals to the DUT, this ground may have to be removed for correct operation of the HPNX or CableCARD.</p> <p>Hpower.7, Hpower.5A</p>	5V±10%		
<p>Utilizing the HPNX, select the appropriate CIS to send a value of 0x3 in the Power field of the Feature Selection Byte (TPCE_FS) from the POD.</p> <p>Hpower.8</p>	<p>The UDRD will ignore the value of 0x3, and provide 3.3vdc on VPP1 and VPP2.</p> <p>OR</p>		
Hpower.8A	<p>The UDRD acknowledges the value of 0x3, and provides 3.3vdc and 5vdc on VPP1 and VPP2, as requested by the POD.</p>		

PICS Coverage for this Procedure

PICS Item	Quality
Hpower.3	Indirect
Hpower.4	Direct
Hpower.5	Direct
Hpower.5A	Direct
Hpower.7	Direct
Hpower.8	Direct
Hpower.8A	Direct

2.1.2 Host-POD Temperature/Average Power Test

The Host must be able to dissipate the heat generated by the POD when running over a period of time.

Equipment: Host under test, Fluke 54 II Thermometer and temperature probe, AC power supply, Reference Thermal POD (Sycard Model 410 REV 01) (The reference Pod will draw a 2.5 Watt average load). Alternative measurement devices can also be used as necessary.

Product name 1: GK-0212-xx Thermo label mini xx: (Temperature is indicated by suffix in the catalogue, the thickness is 0.07mm).

Product name 2: Chino C060 series surface temperature sensor.

Setup: Insert the Reference Thermal POD into Host Connect the AC power supply to the line voltage input.

Attached are the PDF files that describe the Reference Thermal POD



Procedure:

Step	Procedure
1.	With the power load CableCARD laying face up, on the table with the connector towards you, all writing on the CableCARD will be upright and correct left to right. Placement of the temperature probe: Measure up from the connector edge, 39mm Measure from the left (with the CableCARD situated as stated above), 24 mm.

	 <p style="text-align: center;">39mm</p> <p style="text-align: center;">24mm</p>
	<p><u>Temperature probe placement</u></p> <p>Connect one probe so that it dangles above the Host, this probe will measure the ambient temperature.</p>
2.	Place UDRD in environmental chamber, AC power applied, Reference Thermal POD inserted. Set environmental chamber to 40°C. Allow chamber to stabilize.
3.	Leave test running until the POD temperature probe no longer increases in temperature more than 1 degree C over a 2 minute period.
4.	Measure and record ambient temperature reading.
5.	Record the temperature measured on the POD case.

Test Results: Host-POD Temperature/Average Power Test

Measurement	Acceptable Result	Results	Comments
Place UDRD in environmental chamber, AC power applied, Reference Thermal POD inserted. Set environmental chamber to 40°C. Allow chamber to stabilize.	Record values for reference.		
Verify and record the temperature measured on the POD case Hmech.1	The temperature from the probe on the POD case, temperature probe on surface point is not hotter than 65°C		

PICS Coverage for this Procedure

PICS Item	Quality
Hmech.1	Indirect

2.1.3 Host PCMCIA Characteristics Test

This test verifies that the Host exhibits the minimum required PCMCIA card characteristics for successful operation.

Equipment: Host under test, HPNX in Pod Behavior Mode.

Setup: Connect the HPNX to a PCMCIA extender card and bring it to a stable operational state. Operational state is defined as a PC connected to the HPNX (PC running HPNX tool software application). Verify that the Digital Keystone software application running on the PC is connected to the HPNX. Verify the HPNX application is connected to the HPNX hardware. Click Device and select the correct HPNX device and click Connect.

Procedure:

Step	Procedure
1.	Bring up the HPNX software on the given PC, and verify that the PC and HPNX are on the same isolated network.
2.	Under the Device tab, click on the name of the HPNX that you are working with.
3.	Select the “Pod Behavior mode” and click “connect”, then, right click on the Trace window to select (at least) SPDU, TPDU and Payload for full vision of all layers.
4.	On the HPNX GUI click the Test tab. Select POD – “Low level test/ setup” window. In this window in the upper right hand corner click the Right arrow button to start the initialization process between the UDRD and the HPNX.
5.	In the “Low level test/ setup” click “Display”.
6.	Expand the “Low Level State” and the “CIS” data structures under the “State” Tab.
7.	<p>Verify using the HPNX that the UDRD attempts to read the Tuple with code “Config”, CIF subtuple to verify that the data matches the example below (the values in blue must match).</p> <pre> [5] tuple_code = CONFIG [0x1A] tuple_link = 0x1F CONFIGURATION TPCC_SZ RFSZ = 0x0 RMSZ = 0x0 RASZ = 0x1 RFU = 0x0 Index_Last_Entry = 0x00 TPCC_RADR Base_Addr_7_0 = 0x00 Base_Addr_15_8 = 0x02 TPCC_RMSK Mask_Reg_7_0 = 0x00 Subtuples [0] subtuple_code = CIF [0xC0] subtuple_link = 0x17 CIF IFN_SIZE = 0x1 IFN_BASE = 0x01 IFN_1 = 0x03 STR = "OpenCable_POD_V1.00" End_Byte = 0xFF [1] subtuple_code = End [0xFF] End </pre>
8.	Verify that the UDRD writes the value read for both base_addr fields in the tuple into the Configuration Option Register (COR). You verify this in the trace window (selected by choosing the Trace tab) at the end of the CIS table (the step immediately after CARD DETECT). Verify that the message “COR written (...)” is displayed in the “Trace” window
9.	Verify that pull down resistors are used on MCLKO to prevent spurious operation (for 3 rd party testing, this is in the Host Documentation Package).

10. Using the HPNX verify that UDRD has completed hardware initialization by viewing the

Trace window content:

```

device Connected
device Initializing
device Ready
device Insert request
device Inserting
← H CARD DETECT asserted on PCCARD interface
→ H Vcc detected
→ H RESET asserted on PCCARD interface
→ H RESET cleared on PCCARD interface
← H READY asserted on PCCARD interface
→ H COR written (address = 0x0200, value = 0x41)
← H FR bit set on DATA
← H FR bit set on EXTENDED
→ H Set RS on DATA
← H FR bit set on DATA
→ H Set RS on EXTENDED
← H FR bit set on EXTENDED
→ H Set SR on DATA
← H Buffer (128 bytes) Size has been read on DATA channel
→ H Set SW on DATA
→ H Buffer Size (128 bytes) has been written on DATA channel
→ H Set SR on EXTENDED
← H Buffer (128 bytes) Size has been read on EXTENDED channel
→ H Set SW on EXTENDED
→ H Buffer Size (128 bytes) has been written on EXTENDED channel
→ T Create_T_C
device Inserted
← S open_session_request from Resource Manager
← T Create_T_C_Reply
    
```

Trace State Video

PDD Behavioral Mode Version 1.1.2003.10290

“Device Inserted” in the Trace window following hardware negotiation.

Test Results: Host PCMCIA Reset Test

Measurement	Acceptable Result	Results	Comments
Was COR register successfully written? HPPcs.1, HPPii.1, HPPii.4, HPPii.14, HPPii.15, HPPii.5, HPPii.8, HPPcs.7, HPPcs.5, HPPcs.11, HPPii.10, HPPcs.8, HPPcs.9, HPPcs.10	“COR written (...)” displayed		

Measurement	Acceptable Result	Results	Comments
Verify that POD/HOST data and extended channel initialization completes successfully. HPPh.21, HPPh.29, HPPcs.13, HPinit.219, HPinit.220, HPinit.221, HPinit.222, HPinit.223, HPinit.224, HPinit.225, HPinit.228, HPinit.229, DPh.44, DPh.45, DPh.55, DPh.56, DPh.58, DPh.60, DPh.62, DPh.63, DTp.7, DTp.24, DTp.25, DTp.27, DTp.31, ExchP.3, ExchP.4, ExchP.5, ExchP.10, ExchP.11, ExchP.13, ExchP.14, ExchP.15, ExchP.16, ExchP.17, FDCP.6, Hpower.9a, Hpower.9b	"device Inserted" displayed in Trace window		
Pull-down resistor on MCKLO, HPPii.13	Verify that the vendor has submitted documentation Indicating that a pull-down resistor is used on MCKLO to prevent spurious Operation.		

PICS Coverage for this Procedure

PICS Item	Quality
HPPcs.1	Direct
HPPcs.5	Direct
HPPcs.7	Indirect
HPPcs.8	Direct
HPPcs.9	Direct
HPPcs.10	Indirect
HPPcs.11	Indirect
HPPcs.13	Direct
HPPh.21	Indirect
HPPh.29	Indirect
HPPii.1	Indirect
HPPii.4	Indirect
HPPii.5	Direct
HPPii.8	Indirect
HPPii.10	Indirect
HPPii.13	Indirect
HPPii.14	Indirect
HPPii.15	Direct
FDCP.6	Indirect
Hpinit.219	Direct
Hpinit.220	Direct
Hpinit.221	Direct
Hpinit.222	Direct
Hpinit.223	Direct

PICS Item	Quality
Hpinit.224	Direct
Hpinit.225	Direct
Hpinit.228	Direct
Hpinit.229	Direct
DPh.44	Direct
DPh.45	Direct
DPh.55	Direct
DPh.56	Direct
DPh.58	Direct
DPh.60	Direct
DPh.62	Direct
DPh.63	Direct
DTp.7	Direct
DTp.24	Direct
DTp.25	Direct
DTp.27	Direct
DTp.31	Direct
ExchP.3	Direct
ExchP.4	Direct
ExchP.5	Direct
ExchP.10	Direct
ExchP.11	Indirect
ExchP.13	Indirect
ExchP.14	Indirect
ExchP.15	Direct
ExchP.16	Direct
ExchP.17	Indirect
Hpower.9a	Indirect
Hpower.9b	Indirect

2.1.4 Host Control

This test verifies that the POD can successfully control the in-band and out-of-band tuning of the Host and that the Host will only support one Host Control Session.

Equipment: Host (UDRD), HPNX Test tool, Host Control.

Procedure:

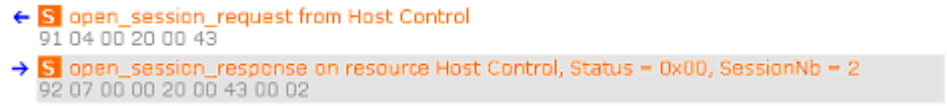
Step	Procedure
1.	Bring up the HPNX software on the given PC, and verify that the PC and HPNX are on the same isolated network.
2.	Under the Device tab, click on the name of the HPNX that you are working with.
3.	Select the "Pod Behavior mode" and click "connect", then, right click on the Trace window to select (at least) SPDU, TPDU and Payload for full vision of all layers.
4.	On the HPNX GUI click the Test tab. Select POD – "Low level test/ setup" window. In this window in the upper right hand corner click the Right arrow button to start the initialization process between the UDRD and the HPNX.
5.	Select "Host Control" tab, click the Right arrow button to start the Host Control resource.
6.	Verify from the HPNX test tool that the "open_session_request()"/"open_session_response()" transaction has completed as shown below. 
7.	Right click on the Host Control session and select Add session slot. Select the play button.
8.	Verify that the UDRD responds to the second open session request with an open_session_response with one of the following session status values. F1 (session not opened, resource exists but unavailable) or F3 (session not opened, resource busy) as defined in EIA-679 page 71 Table 7.

	<p>Using the HPNX test tool, expand the OOB_RX_Tune_req button and send oob_rx_tune() requests with the following parameter values, and verify that for each, the UDRD replies with an oob_rx_tune_cnf() with "tuning granted".</p> <p>Lower Level</p> <p>Frequency = 70000 KHz bit rate = 1544 kbps Spectrum = 0 (non-inv) Frequency= 70000 KHz bit rate = 1544 kbps Spectrum =1 (inv) Frequency= 70000 KHz bit rate = 2048 kbps Spectrum = 0 (non-inv) Frequency= 70000 KHz bit rate = 2048 kbps Spectrum =1 (inv) Frequency= 70000 KHz bit rate = 2048 kbps(b) Spectrum = 0 (non-inv) Frequency= 70000 KHz bit rate = 2048 kbps(b) Spectrum =1 (inv)</p> <p>9. Frequency= 70000 KHz bit rate = 3088 kbps Spectrum = 0 (non-inv) Frequency= 70000 KHz bit rate = 3088 kbps Spectrum =1 (inv)</p> <p>Upper level</p> <p>Frequency= 130000 KHz bit rate = 1544 kbps Spectrum = 0 (non-inv) Frequency= 130000 KHz bit rate = 1544 kbps Spectrum =1 (inv) Frequency= 130000 KHz bit rate = 2048 kbps Spectrum = 0 (non-inv) Frequency= 130000 KHz bit rate = 2048 kbps Spectrum =1 (inv) Frequency= 130000 KHz bit rate = 2048 kbps(b) Spectrum = 0 (non-inv) Frequency= 130000 KHz bit rate = 2048 kbps(b) Spectrum =1 (inv) Frequency= 130000 KHz bit rate = 3088 kbps Spectrum = 0 (non-inv) Frequency= 130000 KHz bit rate = 3088 kbps Spectrum =1 (inv)</p>
<p>10.</p>	<p>Using the HPNX test tool, send oob_rx_tune() requests with the following parameter values, and verify that for each, the UDRD replies with an oob_rx_tune_cnf() with "tuning denied".</p> <p>Frequency out of Range</p> <p>Frequency = 65500 KHz bit rate = 1544 kbps Spectrum = 0 (non-inv) Frequency = 130500 KHz bit rate = 1544 kbps Spectrum = 0 (non-inv)</p>
<p>11.</p>	<p>Using the HPNX test tool, send OOB_TX_tune_req(), and verify that the UDRD replies with an OOB_TX_tune_cnf() with tuning denied - RF Transmitter not physically available (0x01).</p>

Test Results: Host Control Test

Measurement	Acceptable Result	Results	Comments
Verify from the HPNX Test tool data log that the UDRD has reported support for Host control resource with ID = 0x00200043 DApHc.1	open_session_response present as shown above.		
Send another request to the UDRD to open a second session to the Host control resource, and verify that the UDRD rejects the second request DApHc.2	open_session_response reported error as described above		

Measurement	Acceptable Result	Results	Comments
Using the HPNX Test tool, send oob_rx_tune() requests and verify that the UDRD replies back with rf_rx_tune_cnf() with status = tuning granted (00) DApHc.30, DApHc.31, HFDCrf.5, HFDCrf.5a	oob_rx_tune_cnf received with "tuning granted" for each valid request		
Using the HPNX Test tool, send oob_rx_tune() requests and verify that the UDRD replies back with rf_rx_tune_cnf() with status = tuning denied (other than 00) DAPHC.3	oob_rx_tune_cnf received with "tuning denied" for each invalid request		
Using the HPNX Test tool, send OOB_TX_tune_req() and verify that the UDRD replies back with OOB_TX_tune_cnf() with status = tuning denied - RF Transmitter not physically available (0x01) UniDir.3	oob_tx_tune_cnf received with "tuning denied" for each request		

PICS Coverage for this Procedure

PICS Item	Quality
DApHc.1	Direct
DApHc.2	Direct
DAPHC.3	Direct
DApHc.30	Direct
DApHc.31	Direct
UniDir.3	Direct
HFDCrf.5	Direct
HFDCrf.5a	Direct

2.1.5 Host Macrovision Test

This test verifies that the Host can enable analog program copy protection to the NTSC outputs (composite, composite RF, S-video, and “Y of YPbPr”), in accordance with the [Macrovision] standard, for video services carried on a QAM channel, that require POD operation for reception.

Note: This test does not apply to any program that is displayable without POD operation.

Introduction: This test requires that Macrovision is turned-on in the DENC (Digital Encoder) of the Host. Macrovision is also known as anti-taping; it was created to prevent an analog recording device from being able to record a particular (or copyrighted) program. There are 4 basic modes of Macrovision. The specific Macrovision mode to be used with a particular digital stream is defined in the APS code of the CCI bits as shown in the following table:

APS Code	Macrovision Mode	Mode Description
00	0	Macrovision off
01	1	AGC on
10	2	AGC + 2-line color stripe*
11	3	AGC + 4-line color stripe*

* “color stripe” is also referred to as “split burst”

These modes are defined in ANSI/SCTE 41 2004, table 6.1-C APS Value Definitions

Equipment: Host under test, headend [input stream] or HPNX tool with Copy Protection Functionality, oscilloscope with NTSC video triggering capability (or VM700 Video Tester).

Setup: Connect the Host device to the headend. Connect an NTSC demodulator to the RF output (if an RF output exists) and tune the demodulator to the selected RF output channel. For the purpose of all procedures in this section, treat the baseband video output of the NTSC demodulator as an NTSC output of the Host device.

Definition of ‘Verify’: CE manufacturers have already complied with electrical specifications for Macrovision certification. Therefore, for this test section, ‘Verify’ shall be defined as “any video aberration that looks like Macrovision” is present on the video signals, as viewed by an oscilloscope.

Procedure 1: Digital Source Test

Step	Procedure
	Set up Oscilloscope to trigger on a TV line between 10-17 and connect to a standard-definition composite video output.
1.	Bring up the HPNX software on the given PC, and verify that the PC and HPNX are on the same isolated network.
2.	Under the Device tab, click on the name of the HPNX that you are working with.
3.	Select the “Pod Behavior mode” and click “connect”, then, right click on the Trace window to select (at least) SPDU, TPDU and Payload for full vision of all layers.

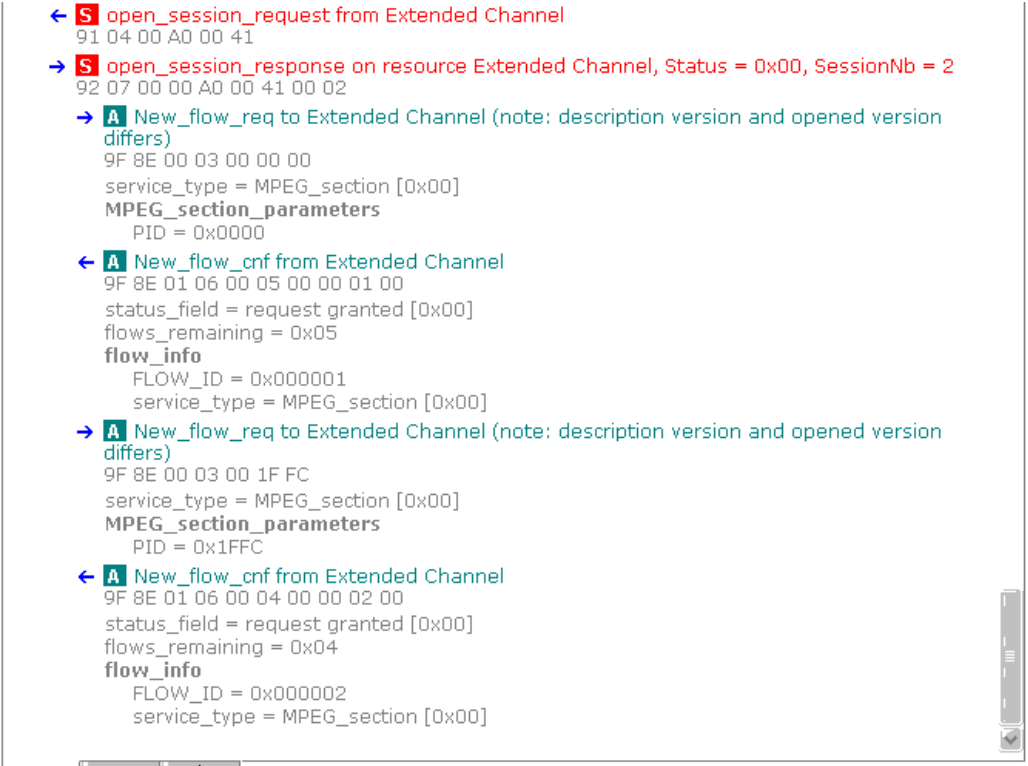
4.	On the HPNX GUI click the Test tab. Select POD – “Low level test/ setup” window. In this window in the upper right hand corner click the Right arrow button to start the initialization process between the UDRD and the HPNX.
5.	Select “Copy Protection ” tab and open the Copy Protection resource by pressing the play button.
6.	Wait for the Copy protection binding procedure to complete with “PBM CopyProtection Session Key successfully generated”.
7.	Expand the “Key Refresh” button and click the “Generate Session Key” button, verify, “PBM CopyProtection Session Key successfully generated.”
8.	Expand the “Extended Channel” tab, depending on the UDRD you may have to change the resource version of the HPNX to match that of the UDRD. Right click on the Session slot. Select “Change Resource Version”. Enter the correct resource version needed to match the UDRD (version 1 or version 2 as defined in SCTE 28 section 8.9). Click OK. On the “Extended channel” tab press the Play button to open the extended channel resource.
9.	<p>Verify that the UDRD issues a New_flow_req to Extended Channel requesting a service_type = MPEG_section with a PID = 0x1FFC. See example below.</p>  <p>Trace State Video</p> <p>POD Behavioral Mode Version 1.0.2003.04270</p> <p>Please note the FLOW_ID assigned by the UDRD in the New_flow_cnf.</p> <p>In this example the FLOW_ID assigned to the PID 0x1FFC MPEG_section flow is 0x000002.</p>
10.	In the “Extended Channel” tab, expand the “Flow Feed” button. Next to the “SI table file” click the Browse button. Select the “Profile1.hex” file from wherever you have stored it on the HPNX, and click “OPEN”.

11.	<p>Enter the FLOW_ID that was noted above, into the Flow ID window and click Send.</p> <p>NOTE: It is imperative that the correct Flow id be used in order for this test to function properly.</p> <p>FYI: In this step immediately after you click Send, the following tables will be sent to the UDRD.</p> <ol style="list-style-type: none"> 1.) Network Information Table with a Carrier Definition table subtype. 2.) Network Information Table with a Modulation Mode table subtype 1. 3.) Network Information Table with a Modulation Mode table subtype 2. 4.) Short Form Virtual Channel Table with a Defined Channel Map subtype. 5.) Short Form Virtual Channel Table with a Virtual Channel Map subtype 1. 6.) Short Form Virtual Channel Table with a Virtual Channel Map subtype 2. 7.) Short Form Virtual Channel Table with a Virtual Channel Map subtype 3. 8.) System Time Table. 9.) Network Text Table with a Source Name Sub-table subtype.
12.	Select "Conditional Access" tab to open the Conditional Access resource by pressing the Play button.
13.	Tune the UDRD to in the clear QAM transport stream.
14.	When the UDRD does a channel change to tune the in the clear QAM, verify it sends a CA_PMT to the HPNX. In the HPNX trace window locate with the CA_PMT message sent by the UDRD and note the value of the "program_number = 0x?????" field. This is the Program number that the Host is tuned to in the transport stream.
15.	Using the oscilloscope, verify that Macrovision is not enabled.
16.	Expand the CCI button to expose the "Analog Protection System" pull down menu.
17.	<p>In the Program Number field type the decimal number that is the same as the Hex value sent by the Host in the CA_PMT message.</p> <p>NOTE: You may have to convert the HEX number that was sent by the UDRD in the CA_PMT to a decimal value.</p>
18.	Select "AGC Process On, Split Burst Off" Click send.
19.	Using the oscilloscope, verify that Macrovision is enabled.
20.	Tune the UDRD to another in-the-clear program.
21.	Using the oscilloscope, verify that Macrovision is disabled.
22.	When the UDRD does a channel change to tune the in the clear QAM, verify it sends a CA_PMT to the HPNX. In the HPNX trace window locate with the CA_PMT message sent by the UDRD and note the value of the "program_number = 0x?????" field. This is the Program number that the Host is tuned to with in the transport stream.
23.	<p>In the Program Number field type the decimal number that is the same as the Hex value sent by the Host in the CA_PMT.</p> <p>NOTE: You may have to convert the HEX number that was sent by the UDRD in the CA_PMT to a decimal value.</p>
24.	Select "AGC Process On, 2 Line Split Burst On" Click send.
25.	Using the oscilloscope, verify that Macrovision is enabled.
26.	Tune the UDRD to another in-the-clear program
27.	Using the oscilloscope, verify that Macrovision is disabled.
28.	When the UDRD does a channel change to tune the in the clear QAM, verify that it sent a CA_PMT to the HPNX. In the HPNX trace window locate with the CA_PMT message sent by the UDRD and note the value of the "program_number = 0x?????" field. This is the Program number that the Host is tuned to with in the transport stream.

29.	In the Program Number field type the decimal number that is the same as the Hex value sent by the Host in the CA_PMT. NOTE: You may have to convert the HEX number that was sent by the UDRD in the CA_PMT to a decimal value.
30.	Select "AGC Process On, 4 Line Split Burst On" Click send.
31.	Using the oscilloscope, verify that Macrovision is enabled.
32.	Select "Copy Protection Encoding Off" Click send.
33.	Using the oscilloscope, verify that Macrovision is disabled.

Test Results: Host Macrovision Test Procedure 1

Measurement	Acceptable Result	Results	Comments
Mode 0 check	No Macrovision found in any NTSC output		
Mode 1 check	Mode 1 present in all NTSC outputs		
Mode 2 check	Mode 2 present in all NTSC outputs*		
Mode 3 check	Mode 3 present in all NTSC outputs*		

* Color stripe (split burst) applies only to composite outputs.

Procedure 2: Proof of Certification

Step	Procedure
1.	Provide documentary proof of Macrovision compliance / certification of the Host device before final production product begins shipping. NOTE: Specific measurements of Macrovision waveform electrical characteristics are not required. Proof of certification implies complete compliance.

Test Results: Host Macrovision Test Procedure 4

Measurement	Acceptable Result	Results	Comments
Documentation HACP.2	Proof of Macrovision certification provided to CableLabs		

PICS Coverage

PICS Item	Quality
HACP.2	Direct

2.1.6 Host Copy Protection and CCI Test

This test is to verify that the copy protection process meets the requirements. The keys for encryption are derived simultaneously in the POD and the Host, and it is the POD that actually performs the encryption. The Host has to decrypt successfully to get a clear picture to put on the TV screen. Short explanations are attempted in the introduction section below to explain the critical steps of the copy protection.

Introduction:

This is a sequential step of generating the 56-bit copy protection key as an input to the DES Electronic Codebook (ECB) algorithm. DES-ECB is not illustrated in detail in SCTE 41 2004, but can be found at the government web site, <http://www.itl.nist.gov/fipspubs/fip46-3.htm>.

For ATP, script software can be written to snoop the various variables below to confirm that each step leading to the CP key generation is met. As to the actual successful key exchange/generation between POD and Host, a clear picture on TV screen of an encrypted channel is a good indication.

Note: Systems parameters must be obtained from various places

- g = Diffie-Hellman base, 1024 bits, licensed from CableLabs
- n = Diffie-Hellman prime, 1024 bits, licensed from CableLabs
- SSK = A shared secret system parameter used by both POD (SSK_P) and Host (SSK_H) to authenticate the exchange of Diffie-Hellman public key parameters.
- Root, Manufacturer, and device X.509 certificates
- DFAST algorithm, licensed from CableLabs
- Host_ID = 40 bits, Host Manufacturer
- POD_ID = 64 bits, POD vendor
- N_{Host} = 64 bits, randomly generated by Host
- N_{module} = 64 bits, randomly generated by POD

I. Generating Parameters

a. Public Keys (1024 bits)

1. POD generates randomly a private exponent x at least 160 bits but less than n
2. Host generates randomly a private exponent y at least 160 bits but less than n
3. POD computes public key $DH_pubkeyP = g^x \text{ mod } n$ and send it to Host

4. Host computes public key $DH_pubkeyH = g^y \text{ mod } n$ and send it to POD

b. Shared secret key DHKey (1024 bits)

1. POD derives $DHkeyP = (DH_pubkeyH)^x \text{ mod } n = \text{Shared DH secret key [DHSK]}$

2. Host derives $DHkeyH = (DH_pubkeyP)^y \text{ mod } n = \text{Shared DH secret key [DHSK]}$

3. DHkeyP must be equal to DHkeyH

c. Validating Host ID

POD module must validate Host ID by comparing the Validated_Host_ID sent by the CA System (headend) with the extracted Host_ID from the X.509 certificate. The certificate contains signature using RSA Digital Signature Algorithm, and the POD must verify this signature on the X.509. The basic signature steps are outlined below.

II. Authenticating Keys (160 bits)

a. POD

$$\text{AuthKeyP} = \text{SHA-1}[\text{DHSK} | \text{Host_ID} | \text{POD_ID}]$$

b. Host

$$\text{AuthKeyH} = \text{SHA-1}[\text{DHSK} | \text{Host_ID} | \text{POD_ID}]$$

III. Hashing Long-term Keys, Ks (128 bits)

a. POD

Using SHA to hash long-term keys AuthKeyP, DHSK, N_module, N_Host resulted in KsP.

$$\text{KsP} = \text{SHA-1}[\text{AuthKeyP} | \{\text{DHSK}\}_{\text{lsb224}} | \text{N_Host} | \text{N_module}]_{\text{first 16 bytes}}$$

b. Host

Using SHA to hash long-term keys AuthKeyH, DHSK, N_module, N_Host resulted in KsH.

$$\text{KsH} = \text{SHA-1}[\text{AuthKeyH} | \{\text{DHSK}\}_{\text{lsb224}} | \text{N_Host} | \text{N_module}]_{\text{first 16 bytes}}$$

IV. Copy Protection Key Generation, Ks_dfast (56 bits)

a. POD

$$\text{Ks_dfastP} = \text{DFAST}[\text{KsP}]$$

b. Host

Ks_dfastH = DFAST[KsH]

The resulting Ks_dfastH should be equal to Ks_dfastP.

Equipment: Host under test, HPNX.

Note: The attached file need to be copied to the computer running the HPNX application,



MOT_STT_CW20.he
x

Procedure : Using HPNX Test Tool

Run HPNX in PBM emulation mode, run the Copy Protection script in full authentication mode.

First time Host-POD binding consists of a communication sequence to generate the matching Copy Protection keys in both Host and POD, and store the intermediate keys in their respective non-volatile memory.

Step	Procedure
1.	Bring up the HPNX software on the given PC, and verify that the PC and HPNX are on the same isolated network.
2.	Under the Device tab, click on the name of the HPNX that you are working with.
3.	Select the "Pod Behavior mode" and click "connect", then, right click on the Trace window to select (at least) SPDU, TPDU and Payload for full vision of all layers.
4.	On the HPNX GUI click the Test tab. Select POD – "Low level test/ setup" window. In this window in the upper right hand corner click the Right arrow button to start the initialization process between the UDRD and the HPNX.
5.	Go to the Application Information tab and click on it. Press the Play button to open the resource.
6.	Go to the Man Machine Interface tab and click on it. Press the Play button to open the resource.
7.	Expand the "Extended Channel" tab, depending on the UDRD you may have to change the resource version of the HPNX to match that of the UDRD. Right click on the Session slot. Select "Change Resource Version". Enter the correct resource version needed to match the UDRD (version 1 or version 2 as defined in SCTE 28 section 8.9). Click OK. On the "Extended channel" tab press the Play button to open the extended channel resource.

<p>8.</p>	<p>Verify that the UDRD issues a New_flow_req to Extended Channel requesting a service_type = MPEG_section with a PID = 0x1FFC. See example below.</p>  <p>Trace State Video</p> <p>POD Behavioral Mode Version 1.0.2003.04270</p> <p>Please note the FLOW_ID assigned by the UDRD in the new_flow_cnf.</p> <p>In this example the FLOW_ID assigned to the PID 0x1FFC MPEG_section flow is 0x000002.</p>
<p>9.</p>	<p>In the “Extended channel ” tab, under the “Flow Feed” function. Next to the “SI table file” click the Browse button. Select the “MOT_STT_CW20.hex” file from wherever you have stored it on the HPNX, and click “OPEN”.</p>
<p>10.</p>	<p>Enter the FLOW_ID that was noted in step 8 into the Flow ID window and click Send. NOTE: It is imperative that the correct Flow id be used in order for this test to function properly.</p> <p>FYI: In this step immediately after you click send, the following tables will be sent to the UDRD. 1.) System Time Table.</p>
<p>11.</p>	<p>Select the Copy Protection tab. Press the Play button.</p>
<p>12.</p>	<p>Verify the HPNX issues an Open_session_request with tag value 91 04 00 B0 00 C1.</p>
<p>13.</p>	<p>Verify Host responds with an Open_session_response with tag value 92 07 00 00 B0 00 C1 yy yy</p> <p>yyyy = session number</p>
<p>14.</p>	<p>Verify the HPNX issues a CP_open_req with tag value 9F 90 00 00.</p>

15.	Verify the Host issues a CP_open_cnf with a tag value 9F9001 04 00000002.
16.	<p>Verify the HPNX issues a CP_data_req sending the POD_DevCert, POD_ManCert , DH_pubkeyP, and the signature of the POD DH public key SIGNp(DH_pubkeyP) and requests from the Host the Host_DevCert, Host_ManCert, DH_pubkeyH and the signature of the Host DH public key SIGNh(DH_pubkeyH). The format for this will be</p> <p>9F9002 82 1113 02 04 10 0800 aa...aa 08 0800 bb...bb 0E 0080 cc...cc 12 0080 dd...dd 04 0F 07 0D 11</p> <p>aa...aa = 2048 bytes of POD_DevCert</p> <p>bb...bb = 2048 bytes of POD_ManCert</p> <p>cc...cc = 128 bytes of DH_pubkeyP</p> <p>dd...dd = 128 bytes of SIGNp(DH_pubkeyP)</p>
17.	<p>Verify the Host responds with a CP_data_cnf providing the Host Certificate, DH_pubkeyH and the signature of the Host DH public key SIGNh(DH_pubkeyH). The format is as follows:</p> <p>9F9003 82 110E 02 04 0F 0800 aa...aa 07 0800 bb...bb 0D 0080 cc...cc 11 0080 dd...dd</p> <p>aa...aa = 2048 bytes of Host_DevCert</p> <p>bb...bb = 2048 bytes of Host_ManCert</p> <p>cc...cc = 128 bytes of DH_pubkeyH</p> <p>dd...dd = 128 bytes of SIGNh(DH_pubkeyH)</p>
18.	<p>Verify the HPNX issues CP_data_req requesting the Host authentication key, AuthKeyH.</p> <p>9F9002 04 02 00 01 16</p> <p>0x16 = 22 = data type id for AuthKeyH</p>
19.	<p>Verify the Host responds with CP_data_cnf providing its authentication key, AuthKeyH.</p> <p>9F9003 19 02 01 16 00 14 xx...xx xx...xx = 20 bytes of AuthKeyH</p>

20.	<p>Verify the HPNX issues CP_data_req sending N_module (POD challenge to Host) and POD_ID, and requesting that the Host send Host_ID and N_Host (Host challenge to POD)</p> <p>(CP Key derivation request)</p> <p>9F9002 1B 02 02 06 00 08 xx...xx 0C 00 08 yy...yy</p> <p>02 05 0B</p> <p>0x1B = 27 bytes</p> <p>xx...xx = 8 bytes of POD_ID</p> <p>yy...yy = 8 bytes of N_module</p>
21.	<p>Verify the Host responds with CP_data_cnf providing the Host_ID and N_Host.</p> <p>9F9003 15 02 02 05 00 05 xx...xx 0B 00 08 yy...yy</p> <p>xx...xx = 5 bytes of Host_ID</p> <p>yy...yy = 8 bytes of N_Host</p>
22.	<p>Verify "PBM CopyProtection Session Key successfully generated" is displayed in HPNX trace window.</p>
23.	<p>The HPNX issues a CP_sync_req (POD-Host sync. request)</p> <p>9F9004 00</p>
24.	<p>The Host responds with a CP_sync_cnf (POD-Host sync. response)</p> <p>9F90005 01 xx</p> <p>xx = 00 O.K. support CP (For this test the Host should always respond with 00).</p> <p>01 not support CP</p> <p>02 Host is busy</p>
25.	<p>Expand the "Extended Channel" tab, depending on the UDRD you may have to change the resource version of the HPNX to match that of the UDRD. Right click on the Session slot. Select "Change Resource Version". Enter the correct resource version needed to match the UDRD (version 1 or version 2 as defined in SCTE 28 section 8.9). Click OK. On the "Extended channel" tab press the Play button to open the extended channel resource.</p>

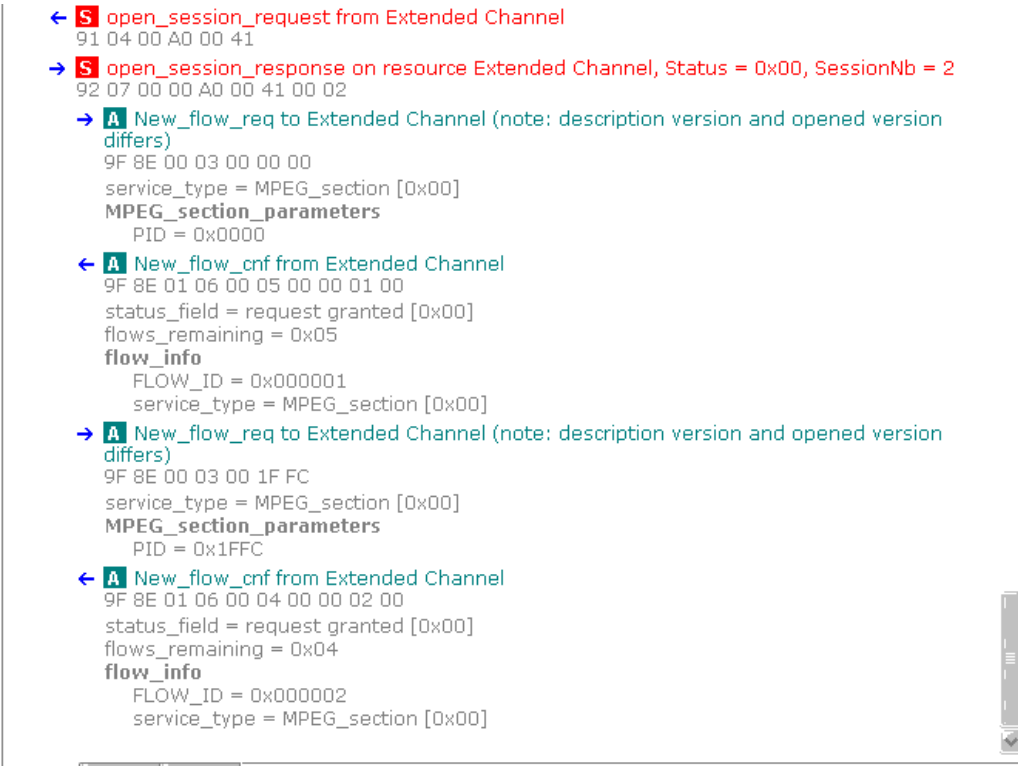
<p>26.</p>	<p>Verify that the UDRD issues a New_flow_req to Extended Channel requesting a service_type = MPEG_section with a PID = 0x1FFC. See example below.</p>  <p>Trace State Video</p> <p>POD Behavioral Mode Version 1.0.2003.04270</p> <p>Please note the FLOW_ID assigned by the UDRD in the New_flow_cnf.</p> <p>In this example the FLOW_ID assigned to the PID 0x1FFC MPEG_section flow is 0x000002.</p>
<p>27.</p>	<p>In the “Extended Channel” tab, expand the “Flow Feed” button. Next to the “SI table file” click the Browse button. Select the “Profile1.hex” file from wherever you have stored it on the HPNX, and click “OPEN”.</p>
<p>28.</p>	<p>Enter the FLOW_ID that was noted above, into the Flow ID window and click Send.</p> <p>NOTE: It is imperative that the correct Flow id be used in order for this test to function properly.</p> <p>FYI: In this step immediately after you click Send, the following tables will be sent to the UDRD.</p> <ul style="list-style-type: none"> 10.) Network Information Table with a Carrier Definition table subtype. 11.) Network Information Table with a Modulation Mode table subtype 1. 12.) Network Information Table with a Modulation Mode table subtype 2. 13.) Short Form Virtual Channel Table with a Defined Channel Map subtype. 14.) Short Form Virtual Channel Table with a Virtual Channel Map subtype 1. 15.) Short Form Virtual Channel Table with a Virtual Channel Map subtype 2. 16.) Short Form Virtual Channel Table with a Virtual Channel Map subtype 3. 17.) System Time Table. 18.) Network Text Table with a Source Name Sub-table subtype.

29.	Select "Conditional Access" tab to open the Conditional Access resource by pressing the Play button.
30.	Tune the UDRD to in the clear QAM transport stream.
31.	When the UDRD does a channel change to tune the in the clear QAM, verify it sends a CA_PMT to the HPNX. In the HPNX trace window locate with the CA_PMT message sent by the UDRD and note the value of the "program_number = 0x?????" field. This is the Program number that the Host is tuned to in the transport stream.
32.	Expand the CCI button to expose the "Digital Copy Permission" pull down menu.
33.	In the Program Number field type the decimal number that is the same as the Hex value sent by the Host in the CA_PMT message. NOTE: You may have to convert the HEX number that was sent by the UDRD in the CA_PMT to a decimal value.
34.	Select "No further copying is permitted" Click send.
35.	Verify the HPNX issues CP_data_req sending a CCI_data, Program_Number and CCI_auth. Requesting from the UDRD the CCI_ack and Program_Number.
36.	Verify the Host responds with CP_data_cnf with the CCI_ack and Program_Number
37.	Verify "CCI_ack verified - CCI delivery completed successfully" is displayed in HPNX trace window.
38.	Connect the 1394 source to a display device without 5C and make sure that Copy protection is being applied to that output source interface by the absence of a picture when CCI is set to any value other than 0x00. If the device has a DVI or HDMI output Connect the DVI or HDMI source to a display device without HDCP and make sure that Copy protection is being applied to that output source interface by the absence of a picture when CCI is set to any value other than 0x00.
39.	Tune the UDRD to another in-the-clear program.
40.	When the UDRD does a channel change to tune the in the clear QAM, verify it sends a CA_PMT to the HPNX. In the HPNX trace window locate with the CA_PMT message sent by the UDRD and note the value of the "program_number = 0x?????" field. This is the Program number that the Host is tuned to in the transport stream.
41.	Expand the CCI button to expose the "Digital Copy Permission" pull down menu.
42.	In the Program Number field type the decimal number that is the same as the Hex value sent by the Host in the CA_PMT message. NOTE: You may have to convert the HEX number that was sent by the UDRD in the CA_PMT to a decimal value.
43.	Select "One Generation Copy is Permitted" Click send.
44.	Verify the HPNX issues CP_data_req sending a CCI_data, Program_Number and CCI_auth. Requesting from the UDRD the CCI_ack and Program_Number.
45.	Verify the Host responds with CP_data_cnf with the CCI_ack and Program_Number
46.	Verify "CCI_ack verified - CCI delivery completed successfully" is displayed in HPNX trace window.

<p>47.</p>	<p>Connect the 1394 source to a display device without 5C and make sure that Copy protection is being applied to that output source interface by the absence of a picture when CCI is set to any value other than 0x00.</p> <p>If the device has a DVI or HDMI output</p> <p>Connect the DVI or HDMI source to a display device without HDCP and make sure that Copy protection is being applied to that output source interface by the absence of a picture when CCI is set to any value other than 0x00.</p>
<p>48.</p>	<p>Tune the UDRD to another in-the-clear program.</p>
<p>49.</p>	<p>When the UDRD does a channel change to tune the in the clear QAM, verify it sends a CA_PMT to the HPNX. In the HPNX trace window locate with the CA_PMT message sent by the UDRD and note the value of the "program_number = 0x?????" field. This is the Program number that the Host is tuned to in the transport stream.</p>
<p>50.</p>	<p>Expand the CCI button to expose the "Digital Copy Permission" pull down menu.</p>
<p>51.</p>	<p>In the Program Number field type the decimal number that is the same as the Hex value sent by the Host in the CA_PMT message.</p> <p>NOTE: You may have to convert the HEX number that was sent by the UDRD in the CA_PMT to a decimal value.</p>
<p>52.</p>	<p>Select "Copying is Prohibited" Click send.</p>
<p>53.</p>	<p>Verify the HPNX issues CP_data_req sending a CCI_data, Program_Number and CCI_auth. Requesting from the UDRD the CCI_ack and Program_Number.</p>
<p>54.</p>	<p>Verify the Host responds with CP_data_cnf with the CCI_ack and Program_Number</p>
<p>55.</p>	<p>Verify "CCI_ack verified - CCI delivery completed successfully" is displayed in HPNX trace window.</p>
<p>56.</p>	<p>Connect the 1394 source to a display device without 5C and make sure that Copy protection is being applied to that output source interface by the absence of a picture when CCI is set to any value other than 0x00.</p> <p>If the device has a DVI or HDMI output</p> <p>Connect the DVI or HDMI source to a display device without HDCP and make sure that Copy protection is being applied to that output source interface by the absence of a picture when CCI is set to any value other than 0x00.</p>
<p>57.</p>	<p>Press the stop button on the Copy Protection window.</p>
<p>58.</p>	<p>Expand the Certificate store button and select "Missing Country Code" from the pull down menu.</p> <p>Note: This functionality is available in Evaluation HPNX version 1.2.2003.12121released 12-12-03 and later.</p>  <p>The screenshot shows a window titled "Copy Protection" with a "Session slot" button. Under the "Certificate Store" section, there is a dropdown menu labeled "Select Certificate Store to use :". The dropdown is open, showing three options: "Valid Certificates", "Missing country Code" (which is highlighted), and "Missing Organization". Below the dropdown are several expandable sections: "Authentication", "Key Refresh", "CCI", "CP_data_req", and "CP_sync_req".</p>

59.	Press the play button on the Copy Protection window, verify that the HPNX and Host fail the copy protection binding process.
60.	Verify that the Host report an error to the user with the following text "Please call your cable operator and report an invalid CableCARD"
61.	Repeat steps 44 through 46 for each invalid certificate in the Certificate store pull down menu.

Test Results: Host Copy Protection Test, Host-POD binding

Measurement	Acceptable Result	Results	Comments
Open_session_response 92 07 00 00 B0 00 81 yy yy CpsB.4, CpsR.1, CpsR.2, CpsR.4	HPNX read out		
CP_open_cnf 9F9001 04 00000002 CpsB.10, CpsR.6	HPNX read out		
CP_data_cnf 9F9003 8n E0 02 02 0F 00 58 xx...xx 0D 00 80 yy...yy CpsB.16, CpsR.8	HPNX read out		
CP_data_cnf 9F9003 19 02 01 16 00 14 xx....xx CpsB.3, CpsB.24	HPNX read out		
CP_data_cnf 9F9003 14 02 02 05 00 05 xx...xx 0B 00 08 yy...yy CpsB.23, CpsK.7, CpsK.10	HPNX read out		
CP_data_cnf 9F9003 12 02 02 13 00 08 xx...xx 1A 00 002 yy yy CpsC.9	HPNX read out		
CP_data_cnf 9F9003 1E 02 02 1C 00 14 xx...xx 1A 00 02 yy yy CpsC.1, CpsC.12, CpsC.13CpsK.9, Cpsk.12, CpsL.6, CpsL.7, CpsL.8, CpsC.4	HPNX read out		
Upon the UDRD's successful completion of Copy Protection binding with the HPNX the following PICS have been "indirectly" satisfied. CertMgt.1 thru CertMgt.16, CertMgt.18A CertMgt.25, CpsT.2, CpsL.1,			

PICS Coverage for this Procedure

PICS Item	Quality
CpsR.1	Direct
CpsR.2	Direct
CpsR.4	Direct
CpsR.6	Direct
CpsR.8	Direct

CpsB.3	Direct
CpsB.4	Indirect
CpsB.10	Direct
CpsB.16	Indirect
CpsB.23	Direct
CpsB.24	Direct
CpsK.7	Direct
CpsK.10	Indirect
CpsK.9	Indirect
CpsK.12	Indirect
CpsL.1	Indirect
CpsL.6	Indirect
CpsL.7	Indirect
CpsL.8	Indirect
CpsC.1	Direct
CpsC.4	Indirect
CpsC.9	Direct
CpsC.12	Indirect
CpsC.13	Indirect
CpsT.2	Direct
CertMgt.1	Indirect
CertMgt.2	Indirect
CertMgt.3	Indirect
CertMgt.3a	Indirect
CertMgt.3b	Indirect
CertMgt.3c	Indirect
CertMgt.3d	Indirect
CertMgt.4	Indirect
CertMgt.4a	Indirect
CertMgt.4b	Indirect
CertMgt.10	Indirect
CertMgt.11	Indirect
CertMgt.12	Indirect
CertMgt.14	Indirect
CertMgt.16	Indirect
CertMgt.18A	Indirect
CertMgt.25	Indirect
CertMgt.26	Vendor Submitted Documentation
CpsB.27	Direct
CpsB.27a	Direct

2.1.7 UDRD RF Input Return Loss Test

Introduction: This test verifies the UDRD RF Input Return Loss meets the required spec over the full tuning range

Equipment: UDRD under test, HP8753D network analyzer with 75 ohm input impedance, HP85039B Type F calibration kit or equivalent

Setup: Setup the network analyzer as described below

Procedure:

2.1.7.1 Calibration of Return Loss

1. Power on the network analyzer and press the **PRESET** button
2. Set the frequency to cover the range of 54 to 864 MHz as follows: Press **START 54 M/u** and then **STOP 864 M/u**.
3. Set the power to 0 dBmV by pressing **MENU Power, -48.75 xI**. This step will set the output power to -48.75 dBm, which is approx. 0 dBmV.
4. Decrease the IF bandwidth by pressing **AVG IF BW**. Press the down arrow button twice to set the bandwidth to 300 Hz.
5. Change the display resolution and reference position as follows: Press **SCALE REF Reference Position**. Press the up arrow button 3 times to move the 0 dB reference to the eight division. Change the scale by pressing **SCALE/DIV** and pressing the down arrow button twice to obtain 2 dB/div.
6. Press **MEAS Refl:Fwd S11(A/R)**
7. Press **CAL Cal Kit -> Select Cal Kit -> User Kit -> Return -> Return -> Calibrate Menu -> S11 1-Port**
8. Attach the N(m) to F(f) adapter from the calibration kit, P/N 85039-60013, to the test port on the analyzer.
9. Attach the F-cable which will be used to feed the UDRD. The calibration loads will be placed at the UDRD side of that cable.
10. Attach an F-81 barrel to the end of the cable (input to the UDRD).
11. Attach the F(f) OPEN from the calibration kit, P/N 85039-60005, to the F adapter and press **OPEN(F)**.
12. Attach the F(f) SHORT from the calibration kit, P/N 85039-60003, to the F adapter and press **SHORT(F)**.

13. Attach the F(f) LOAD from the calibration kit, P/N 85039-60004, to the F adapter and press *LOAD*.
14. Press *DONE I-PORT CAL*.
15. *After the calibration is complete, verify that the trace is now at the bottom line of the display when the calibrated load is attached.*

2.1.7.2 Measurement of Return Loss

1. Power on UDRD and tune to mid channel.
2. Connect the cable input port of the UDRD directly to the network analyzer test port. Place a marker on the highest point on the measurement trace. The return loss should be greater than or equal to 3 dB.

Test Results: UDRD Input Return Loss Test

Measurement	Acceptable Result	Results	Comments
RF Input Return Loss HFATrf.6, HFATrf.7	3 dB minimum over full tuning range		

PICS Coverage for this Procedure

PICS Item	Quality
HFATrf.6	Direct
HFATrf.7	Indirect

Test Results: UDRD Spurious Emissions Test

Measurement	Acceptable Result	Results	Comments
Spurious Emissions	< -30 dBmV over the range 54 MHz to 864 MHz and -26 dBmV over the range 5 MHz up to but not including 54 MHz		

PICS Coverage for this Procedure

PICS Item	Quality
UniDir.1	Direct

2.1.9 FAT Channel LO Leakage Test

NOTE: This section only applies to UDRD's sold or marketed after July 1, 2005

Introduction: This test verifies that the amount of local oscillator power leaking out of a UDRD device and back into the cable plant is within spec limits.

Equipment: UDRD, HP8561E spectrum analyzer

NOTE: This test only applies to UDRD devices using a single conversion type RF tuner where the local oscillator frequency is separated from the desired video carrier by an amount equal to the IF frequency. If the UDRD device employs a dual conversion type RF tuner the local oscillator frequencies are typically above the entire input range and therefore the test is not applicable.

Procedure:

Step	Procedure
1.	Connect the powered up UDRD under test, and the 75 ohm input of the spectrum analyzer
2.	Tune the UDRD to the 1 st EIA channel listed in Table 2.1.10
3.	Set the spectrum analyzer center frequency to the value specified in the column labeled Video Carrier from Table 2.1.10
4.	Set the spectrum analyzer frequency span to 1 MHz
5.	Change the spectrum analyzer amplitude units to dBmV
6.	Set the spectrum analyzer reference level to 0 dBmV
7.	Set the spectrum analyzer video bandwidth to 300 Hz
8.	Set resolution bandwidth to 9 KHz.
9.	Measure the level at the corresponding LO frequency
10.	Repeat this test for the Video Carriers listed in Table 2.1.10.

EIA channel designation	Video Carrier (MHz)	LO Freq (MHz)	LO level (dBmV)
2	55.25	101	
17	139.25	185	
23	217.25	263	
36	295.2625	341.0125	
49	373.2625	419.0125	
63	457.25	503	
76	535.25	581	
89	613.25	659	

EIA channel designation	Video Carrier (MHz)	LO Freq (MHz)	LO level (dBmV)
108	697.25	743	
121	775.25	821	

Table 2.1.10

Test Results: FAT Channel LO Leakage Test

Measurement	Acceptable Result	Results	Comments
LO Leakage	< -30 dBmV over 54 MHz to 864 MHz		

PICS Coverage for this Procedure

PICS Item	Quality
UniDir.1	Direct

2.1.10 Direct Pickup and Radiated Emissions

Introduction: This test verifies that the UDRD device limits the amount of direct pickup (ingress) and limits the amount of cable signals re-radiated from the device (egress).

Equipment: Host Documentation Package submitted by vendor

NOTE: Documentation may include FCC laboratory test results. Lab results are typically available late in the product development cycle and may be provided just prior to production.

Procedure:

Step	Procedure
1.	Provide documentary proof that the UDRD meets the requirements of 47 CFR 15.118 (c)(3) Direct pickup interference.
2.	Provide documentary proof that the UDRD meets radiated emissions limits caused by cable signals on the product's cable RF connector input in accordance with 47 CFR 76.605 (12) (15 uV/m at 30 m for frequencies outside the range 54 to 216 MHz and 20 uV/m at 3 m for frequencies inside the range 54 to 216 MHz).

Test Results: Direct Pickup and Radiated Emissions

Measurement	Acceptable Result	Results	Comments
Documentation HMech.31	Proof of Direct Pickup compliance.		
Documentation HMech.7	Proof of 47 CFR 76.605 (12) radiated emission compliance.		

PICS Coverage for this Procedure

PICS Item	Quality
HMech.7	Direct
HMech.31	Direct

2.2 Second Group Test Procedures

2.2.1 Host-POD Interface Visual Test

This test verifies that certain physical conditions are met

Equipment: Type I card, Type II card, and PC Card Standard Volume 3

Setup: None

Procedure: With no AC power applied to the UDRD, ensure the HPNX extender (Type II) and the PCCextend 140A (www.sycard.com - Type I) will mate with the UDRD.

Test 1: Host-POD Interface Visual Test:

Measurement	Acceptable Result	Results	Comments
Host accepts Type I & Type II card HPPh.1, HPPh.3, HPPh.4	Card slides easily in and out of POD slot		

Test 2: Vendor Submitted; Host-POD Interface Visual Test:

Measurement	Acceptable Result	Results	Comments
Connector Reliability Test HPPh.6	Verify that the <u>vendor has submitted</u> documentation indicating that the POD connector meets the reliability standards of section 7 of PC Card Standard, Volume 3. Review vendor submitted documentation.		
Connector Durability Test HPPh.7	Verify that the <u>vendor has submitted</u> documentation indicating that the POD connector meets the durability standards of section 8.2 of PC Card Standard, Volume 3 Review vendor submitted documentation.		

PICS Coverage for this Procedure

PICS Item	Quality
HPPh.1	Direct
HPPh.3	Direct
HPPh.4	Direct
HPPh.6	Indirect

PICS Item	Quality
HPPh.7	Indirect

2.2.2 Host Data Channel Multi-Layer Test

This test verifies that the Host successfully implements the link/transport/session/application layer protocols on the data channel.

Equipment: Host (UDRD), HPNX

Procedure:

Step	Procedure
1.	Bring up the HPNX software on the given PC, and verify that the PC and HPNX are on the same isolated network.
2.	Under the Device tab, click on the name of the HPNX that you are working with.
3.	Select the "Pod Behavior mode" and click "connect", then, right click on the Trace window to select (at least) SPDU, TPDU and Payload for full vision of all layers.
4.	On the HPNX GUI click the Test tab. Select POD – "Low level test/ setup" window. In this window in the upper right hand corner click the Right arrow button to start the initialization process between the UDRD and the HPNX.
5.	On the HPNX set 256 bytes for each data channel and extended channel buffer size
6.	<p>Verify from the trace window that the buffer size negotiation is set to 256 bytes (Decimal) both in the data channel and the extended channels. Example (default values shown):</p> <pre> ← H Buffer (256 bytes) Size has been read on DATA channel → H Set SW on DATA → H Buffer Size (256 bytes) has been written on DATA channel → H Set SR on EXTENDED ← H Buffer (256 bytes) Size has been read on EXTENDED channel → H Set SW on EXTENDED → H Buffer Size (256 bytes) has been written on EXTENDED channel </pre> <p>(The value displayed in the trace window is the final negotiated value.)</p>
7.	<p>Verify that the UDRD opens a transport connection for the data channel using Create_TC TCid=1 with a TC tag value 0x82. Example (The TPDU tag value is the first byte of the TPDU.):</p> <pre> → T Create_T_C 82 01 01 </pre> <p>Note: the UDRD may need to be activated (taken out of 'standby' state) for this to happen</p>
8.	<p>Note that the HPNX sends a Create_TC_reply back to the UDRD. Example:</p> <pre> ← T Create_T_C_Reply 83 01 01 </pre>
9.	Note that the HPNX issues an open session request from the Resource Manager with a tag value of 0x91 and resource_identifier value of 0x00010041

10.	<p>Verify that UDRD responds with <code>open_session_response_tag = 0x92</code>, a <code>resource_identifier</code> value of <code>0x00010041</code> and <code>session_nb</code> of <code>YYYY</code>. (The SPDU tag value is the first byte of the SPDU.) Example:</p> <pre>→ S open_session_response on resource Resource Manager, Status = 0x00, SessionNb = 1 92 07 00 00 01 00 41 00 01</pre>
11.	Verify Host Resource Manager sends a <code>profile_inq</code> APDU to HPNX with <code>Profile_inq_tag</code> value of <code>0x9F8010</code> . (The APDU tag value is the first three bytes of the APDU.)
12.	Note that the HPNX replies to the UDRD with <code>Profile_reply_tag</code> value of <code>0x9F8011</code>
13.	Verify UDRD sends a <code>profile_changed</code> APDU with <code>profile_changed_tag</code> value of <code>0x9F8012</code>
14.	Note that the HPNX sends a <code>profile_inq</code> APDU with a <code>profile_inq_tag</code> value of <code>0x9F8010</code> to request information on the available resources from the UDRD.
15.	Verify UDRD then replies with a <code>profile_reply</code> APDU with a <code>profile_reply_tag</code> value of <code>0x9F8011</code> and provides the resource identifiers of the available resources.
16.	<p>Verify link PDU syntax. This means to verify that APDU payloads are in the correct form (e.g., follow a “<code>session_number</code>” body in the SPDU). Example:</p> <pre>→ S session_number (incoming APDU) on Session Nb 1 (Resource Manager) 90 02 00 01 9F 80 10 00 → A profile_inq to Resource Manager 9F 80 10 00 ← A profile_reply from Resource Manager 9F 80 11 00 resource_list ← S session_number on Session Nb 1 (Resource Manager) 90 02 00 01 9F 80 11 00</pre> <p>Note: In the above example, a “<code>profile_inq</code>” APDU (<code>9F 80 10 00</code>) transmitted by the UDRD is preceded by the “<code>session_number</code>” session header (<code>90 02 00 01</code>). The “<code>profile_reply</code>” APDU generated by the HPNX is then prep ended by an identical session header before it sent to the UDRD.</p> <p>Note: HPNX does not display either TPDU (except Command TPDU) or LPDU because the amount of traces generated would go beyond almost any computer capacity. Physical transactions, LPDUs, TPDU, SPDU, APDU are STRICTLY checked by HPNX. If any error appears, an error message is displayed in Traces. If no errors are displayed, everything is correct.</p>
17.	Right click on the Resource Manager tab. Select “ <code>add session slot</code> ”. Click the Play button beside the new Resource Manager Session slot.
18.	Verify that the UDRD responds with <code>open_session_response_tag = 0x92</code> , the proper resource identifier value and a session # <code>YYYY</code> 16-bit unique identifier.
19.	Expand the Resource Manager tab and close the Resource Manager Resource by clicking on the “Stop” button. Note that the HPNX closes the opened sessions by issuing a <code>close_session_request</code> with a tag value of <code>0x95</code>
20.	Verify the UDRD replies to these close requests by issuing a <code>close_session_response</code> with a tag value of <code>0x96</code> .
21.	In the HPNX click the Low Level Test/Set up tab and click the Testing button to expose the <code>Delete_T_C</code> function. Press the Send button. Note that the HPNX closes the transport connection by issuing <code>delete_t_c</code> with a tag value of <code>0x84</code> .
22.	Verify the UDRD closes the connection by replying with a <code>delete_t_c_reply</code> with a tag value of <code>0x85</code> .

Test Results: Host Data Channel Link/Transport/Session/Application Layer Test

Measurement	Acceptable Result	Results	Comments
Verify the UDRD opens a transport connection for the data channel using create_t_c tag value 0x82 HPinit.234, DTp.2, DTp.19, DTp.28, DTp.30, DTp.40, DTp.41, DTp.45, DTp.49, DApRm.3, DTp.3, DTp.21, DTp.23	HPNX read out		
Verify link PDU syntax DLk.4, DSs.3, DApGn.18, DLk.1, DLk.3	HPNX read out		
Verify that UDRD responds with open_session_response_tag = 0x92, a resource_identifier value of 0x00010041 and session_nb of YYYY. HPinit.235, DApRm.1, DApRm.2 DSs.1, DSs.2, DSs.8, DSs.9, DSs.10, DSs.11, DSs.18	HPNX read out		
Verify Host Resource Manager sends a Profile Inquiry to POD with Profile_inq_tag value of 0x9F8010 HPinit.236, DApRm.4	HPNX read out		
Verify UDRD sends a profile_changed APDU with profile_changed_tag value of 0x9F8012 HPinit.237, DApRm.8	HPNX read out		
Verify UDRD then replies with profile_reply_tag value of 0x9F8011. HPinit.238, DApGn.1, DApGn.2, DApGn.3, DApGn.5, DApGn.7, DApGn.8, DApGn.9, DApGn.13, DApGn.14, DApRm.10, HPinit.239, DSs.7	HPNX read out		
Verify the UDRD replies to close session requests by issuing a Tclose_session_response with a tag value of 0x96 DSs.14, DSs.15, DSs.16	HPNX read out		
Verify the HPNX closes the transport connection by issuing delete_t_c with a tag value of 0x84 DTp.12	HPNX read out		
Verify the UDRD closes the transport connection by replying with a delete_t_c_reply with a tag value of 0x85 DTp.13, DTp.34, DTp.35, DTp.37, DTp.47, DTp.11, DTp.48, DTp.32, DTp.36	HPNX read out		
Verify the UDRD splits the data field of a C_TPDU in to several blocks of smaller sizes if required by the transmission buffer size of the Host DTp.8	HPNX read out		
Verify that the UDRD starts each TPDU in a new LPDU (the last fragment of the previous TPDU on a Transport Connection cannot also carry the first fragment of the	HPNX read out		

Measurement	Acceptable Result	Results	Comments
next one). DLK.6			
The Host shall return the actual resource_identifier of the resource requested, with the current version number. DSs.19	HPNX read out		
The session_number object shall always precede a body of the SPDU containing APDU DApGn.16, DSs.17	HPNX read out		

PICS Coverage for this Procedure

PICS Item	Quality
HPinit.234	Direct
HPinit.235	Direct
HPinit.236	Direct
HPinit.237	Direct
HPinit.238	Direct
HPinit.239	Direct
DLK.1	Direct
DLK.3	Direct
DLK.4	Direct
DLK.6	Direct
DTP.2	TBD
DTP.3	Indirect
DTP.8	Indirect
DTP.12	Direct
DTP.13	Direct
DTP.19	Direct
DTP.21	Direct
DTP.23	Direct
DTP.28	Direct
DTP.30	Direct
DTP.34	Indirect
DTP.35	Direct
DTP.11	Direct
DTP.48	Indirect
DTP.32	Indirect
DTP.36	Indirect
DTP.37	Direct
DTP.40	Indirect
DTP.41	Direct
DTP.45	Indirect
DTP.47	Indirect
DTP.49	Indirect
DSs.1	Direct
DSs.2	Direct
DSs.3	Direct
DSs.7	Direct

PICS Item	Quality
DSs.8	Direct
DSs.9	Direct
DSs.10	Direct
DSs.11	Direct
DSs.14	Direct
DSs.15	Direct
DSs.16	Direct
DSs.17	Direct
DSs.18	Direct
DSs.19	Direct
DAPRm.1	Direct
DAPRm.2	Direct
DAPRm.3	Direct
DAPRm.4	Direct
DAPRm.8	Direct
DAPRm.10	Direct
DAPGn.1	Direct
DAPGn.2	Direct
DAPGn.3	Direct
DAPGn.5	Direct
DAPGn.7	Direct
DAPGn.8	Direct
DAPGn.9	Direct
DAPGn.13	Direct
DAPGn.14	Direct
DAPGn.16	Direct
DAPGn.18	Direct

2.2.3 Initialization Error Detection and Handling

Introduction: This test verifies the Hosts supports initialization error condition detection and reporting.

Equipment: Host under test (UDRD), monitor if needed, and HPNX Test tool.

Procedure:

Step	Procedure
1.	Bring up the HPNX software on the given PC, and verify that the PC and HPNX are on the same isolated network.
2.	Under the Device tab, click on the name of the HPNX that you are working with.
3.	Select the "Pod Behavior mode" and click "connect", then, right click on the Trace window to select (at least) SPDU, TPDU and Payload for full vision of all layers.
4.	On the HPNX GUI click the Test tab. Select POD – "Low level test/ setup" window. In this window in the upper right hand corner click the Right arrow button to start the initialization process between the UDRD and the HPNX.
5.	Expand the POD- Low level test/setup.
6.	Expand the Settings button.
7.	Check the "Do not assert Ready" Button.
8.	On the POD- Low Level test/setup press the Play button.
9.	In the Trace window or Host display, verify that the Host performs one of the following actions: 1) Report error using screen in figure (SCTE28 2003 figure E.1-1) if not successful. 2) Retry up to two times and then report error using screen in figure (SCTE28 2003 figure E.1-1), or 3) Report error, but continue to perform PCMCIA resets
10.	On the POD- Low Level test/setup press the Stop button.
11.	Uncheck the "Do not assert Ready" Button.
12.	On the POD- Low Level test/setup under the Settings button click the CIS pull down menu and select "Invalid CIS (fields)".
13.	On the POD- Low Level test/setup press the Play button.
14.	In the Host display, verify that the Host reports the error using screen in figure (SCTE28 2003 figure E.1-1).
15.	On the POD- Low Level test/setup press the Stop button.
16.	On the POD- Low Level test/setup under the Settings button click the CIS pull down menu and select "DK".
17.	Check the "Do not assert initial FR after RS" Button.
18.	On the POD- Low Level test/setup press the Play button.
19.	In the Trace window or Host display, verify that the Host performs one of the following actions: 1) Report error using screen in figure (SCTE28 2003 figure E.1-1) if not successful. 2) Retry up to two times and then report error using screen in figure (SCTE28 2003 figure E.1-1), or 3) Report error, but continue to perform PCMCIA resets
20.	On the POD- Low Level test/setup press the Stop button.

21.	Uncheck the "Do not assert initial FR after RS" Button.
22.	On the POD- Low Level test/setup under the Settings button set the Data Channel Max. Buffer size to 10.
23.	On the POD- Low Level test/setup press the Play button.
24.	In the Trace window or Host display, verify that the Host performs one of the following actions. 1) Report error using screen in figure (SCTE28 2003 figure E.1-1) if not successful. 2) Retry up to two times and then report error using screen in figure (SCTE28 2003 figure E.1-1), or 3) Operate with smaller buffer size.
25.	On the POD- Low Level test/setup press the Stop button.
26.	On the POD- Low Level test/setup under the Settings button set the Extended Channel Max. Buffer size to 10. Change Data Channel Max. Buffer size back to >= 16
27.	On the POD- Low Level test/setup press the Play button.
28.	In the Trace window or Host display, verify that the Host performs one of the following actions. 1) Report error using screen in figure (SCTE28 2003 figure E.1-1) if not successful. 2) Retry up to two times and then report error using screen in figure (SCTE28 2003 figure E.1-1), or 3) Operate with smaller buffer size.
29.	On the POD- Low Level test/setup press the Stop button.
30.	On the POD- Low Level test/setup under the Settings, Check the "Do not reply to create_t_c" button. Change Extended Channel Max. Buffer size back to >= 16.
31.	On the POD- Low Level test/setup press the Play button.
32.	In the Trace window or Host display, verify that the Host performs one of the following actions. 1) Report error using screen in figure (SCTE28 2003 figure E.1-1) if not successful. 2) Retry up to two times and then report error using screen in figure (SCTE28 2003 figure E.1-1), or 3) Report error, but continue to perform PCMCIA resets
33.	On the POD - Low Level test/setup press the Stop button.
34.	Uncheck the "Do not reply to create_t_c" button.
35.	On the Resource Manager, right click on the Session slot. In the menu that appears check "Block outgoing APDU's"
36.	On the POD- Low Level test/setup press the Play button.
37.	In the Trace window or Host display, verify that the Host performs one of the following actions. 1) Report error using screen in figure (SCTE28 2003 figure E.1-1) if not successful. 2) Retry up to two times and then report error using screen in figure (SCTE28 2003 figure E.1-1), or 3) Report error, but continue to perform PCMCIA resets
38.	On the POD - Low Level test/setup press the Stop button.
39.	On the Resource Manager, right click on the Session slot. In the menu that appears uncheck "Block outgoing APDU's"
40.	On the Conditional Access resource, right click on the Session slot. In the menu that appears check "Block outgoing APDU's". Right click on the Session slot again and check "Auto Open".
41.	On the POD- Low Level test/setup press the Play button.
42.	On the Conditional Access resource, click the Play button.

43.	In the Trace window verify that the Host performs one of the following actions. 1) Report error using screen in figure (SCTE28 2003 figure E.1-1) if not successful. 2) Retry up to two times and then report error using screen in figure (SCTE28 2003 figure E.1-1), or 3) Report error, but continue to perform PCMCIA resets
44.	On the Conditional Access resource, press the Stop button.
45.	On the Conditional Access resource, right click on the Session slot. In the menu that appears uncheck "Block outgoing APDU's". Right click on the Session slot again and uncheck "Auto Open"

Test Results: Initialization Error Detection and Handling

Measurement	Acceptable Result	Results	Comments
POD READY signal does not go active HPinit.248	The Host should: 1) Report error 2) Retry up to two times and then report error. Or 3) Report error, but continue to perform PCMCIA resets		_____
POD has incorrect CIS values HPinit.249	The Host should: 1) Report error		_____
Host Device sets data channel RS bit but POD fails to set FR bit within 5 second timeout. HPinit.250, HPinit.251	The Host should: 1) Report error 2) Retry up to two times and then report error. Or 3) Report error, but continue to perform PCMCIA resets		_____
Invalid buffer negotiation – POD data channel (buffer size < 16). HPinit.252	The Host should: 1) Report error 2) Retry up to two times and then report error. Or 3) Operates with smaller size (< 16)		
Invalid buffer negotiation – POD extended channel (buffer size < 16). HPinit.254	The Host should: 1) Report error 2) Retry up to two times and then report error. Or 3) Operates with smaller size (<16)		

Measurement	Acceptable Result	Results	Comments
POD does not respond to Host Device open transport request within 5 seconds. HPinit.255	The Host should: 1) Report error 2) Retry up to two times and then report error. Or 3) Report error, but continue to perform PCMCIA resets		
POD fails to respond to profile_inq within 5 seconds. HPinit.262	The Host should: 1) Report error 2) Retry up to two times and then report error. Or 3) Report error, but continue to perform PCMCIA resets		
POD fails to respond to ca_info_inq within 5 seconds. HPinit.279	The Host should: 1) Report error 2) Retry up to two times and then report error. Or 3) Report error, but continue to perform PCMCIA resets		
POD fails to respond to any request within 5 seconds.	Host Device performs POD reset up to two times and reports the error.		

PICS Coverage for this Procedure:

HPinit.248	Direct
HPinit.249	Direct
HPinit.250	Direct
HPinit.251	Direct
HPinit.252	Direct
HPinit.254	Direct
HPinit.255	Direct
HPinit.262	Direct
HPinit.279	Direct
HPinit.288	Vendor Submitted Documentation
HPinit.289	Vendor Submitted Documentation
HPinit.291	Vendor Submitted Documentation
HPinit.292	Vendor Submitted Documentation
HPinit.293	Vendor Submitted Documentation

HPinit.294	Vendor Submitted Documentation
HPinit.295	Vendor Submitted Documentation

2.2.4 Host Conditional Access Resource Test

This test verifies that the Conditional Access Resource is present and functioning properly.

Equipment: Host (UDRD), HPNX Test tool.

Procedure:

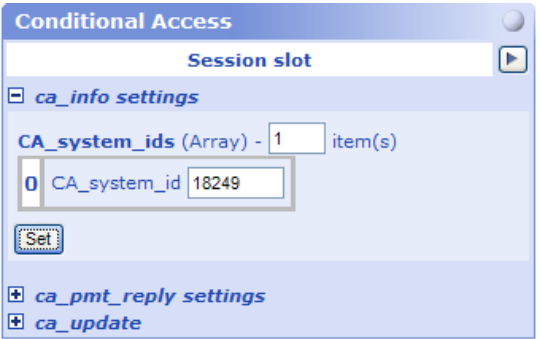
Step	Procedure
1.	Bring up the HPNX software on the given PC, and verify that the PC and HPNX are on the same isolated network.
2.	Under the Device tab, click on the name of the HPNX that you are working with.
3.	Select the "Pod Behavior mode" and click "connect", then, right click on the Trace window to select (at least) SPDU, TPDU and Payload for full vision of all layers.
4.	On the HPNX GUI click the Test tab. Select POD – "Low level test/ setup" window. In this window in the upper right hand corner click the Right arrow button to start the initialization process between the UDRD and the HPNX.
5.	Press Play button on the POD- Low-level test/setup.
6.	Note that the HPNX successfully established the resource manager session; this may be found by opening the Resource Manager tab and ensuring there is a green circle to the right of the Resource manager title bar. The other option is to scroll and look for the "open_session_response on resource Manager, Status =0x00, Session Nb = 1".
7.	Set the ca_system_id value on the HPNX to the Motorola CA system ID = 18249 (decimal) Example: 
8.	Select "Conditional Access" tab, press the Play button to open the conditional access resource.
9.	Verify that the UDRD reports support for Conditional Access resource with ID 0x00030042. This may be verified by scrolling down the trace window screen just past "Resource List". EXAMPLE: "Open Session response to CA support, state=0x00, session number = 2".
10.	Verify that the UDRD issues a CA _Info_Inquiry() to the HPNX.
11.	Note that the UDRD receives a ca_info APDU from the HPNX.
12.	Expand the "Extended Channel" tab, depending on the UDRD you may have to change the resource version of the HPNX to match that of the UDRD. Right click on the Session slot. Select "Change Resource Version". Enter the correct resource version needed to match the UDRD (version 1 or version 2 as defined in SCTE 28 section 8.9). Click OK. On the "Extended channel" tab press the Play button to open the extended channel resource.

<p>13.</p>	<p>Verify that the UDRD issues a New_flow_req to Extended Channel requesting a service_type = MPEG_section with a PID = 0x1FFC. See example below.</p>  <p>Trace State Video</p> <p>POD Behavioral Mode Version 1.0.2003.04270</p> <p>Please note the FLOW_ID assigned by the UDRD in the New_flow_cnf.</p> <p>In this example the FLOW_ID assigned to the PID 0x1FFC MPEG_section flow is 0x000002.</p>
<p>14.</p>	<p>In the “Extended Channel” tab, expand the “Flow Feed” button. Next to the “SI table file” click the Browse button. Select the “Profile1.hex” file from wherever you have stored it on the HPNX, and click “OPEN”.</p>
<p>15.</p>	<p>Enter the FLOW_ID that was noted above, into the Flow ID window and click Send.</p> <p>NOTE: It is imperative that the correct Flow id be used in order for this test to function properly.</p> <p>FYI: In this step immediately after you click Send, the following tables will be sent to the UDRD.</p> <ol style="list-style-type: none"> 1. Network Information Table with a Carrier Definition table subtype. 2. Network Information Table with a Modulation Mode table subtype 1. 3. Network Information Table with a Modulation Mode table subtype 2. 4. Short Form Virtual Channel Table with a Defined Channel Map subtype. 5. Short Form Virtual Channel Table with a Virtual Channel Map subtype 1. 6. Short Form Virtual Channel Table with a Virtual Channel Map subtype 2. 7. Short Form Virtual Channel Table with a Virtual Channel Map subtype 3. 8. System Time Table. 9. Network Text Table with a Source Name Sub-table subtype.

16.	On the UDRD using the channel up and down buttons or the remote control, verify that the channel map has been successfully loaded and that the UDRD can navigate the channel map, and tune to an scrambled or in-the-clear containing CA info digital channel.
17.	Verify that the UDRD issues a ca_pmt() object to the HPNX. Verify that the syntax is correct.
18.	If the UDRD sends a ca_pmt with ca_pmt_cmd_id set to "query", then note that the HPNX sends a ca_pmt_reply() to the UDRD with the CA_enable flag set to 0x0. If the UDRD sends a ca_pmt with ca_pmt_cmd_id set to "ok_mmi", then note that the HPNX may send a ca_pmt_reply() to the UDRD with the CA_enable flag set to 0x0.
19.	If the UDRD sends a ca_pmt with ca_pmt_cmd_id set to ok_descrambling, then the HPNX does not respond.
20.	If the ca_pmt sent has ca_pmt_cmd_id set to one of the following "query or ok_mmi", then on the HPNX under the Conditional Access tab click the Stop button. Under the ca_pmt_reply settings expand the "ca_enable for program and elementary streams" pull down window. Select "Possible under conditions (purchase dialog)". Under the Conditional Access tab click the Play button. Note: This step is necessary to set up the HPNX ca_pmt_reply auto-response setting.
21.	Tune the UDRD to an scrambled or in-the-clear digital containing CA info channel and verify that the UDRD issues a ca_pmt() APDU to the HPNX
22.	If the UDRD sends a ca_pmt with ca_pmt_cmd_id set to "query", then note that the HPNX sends a ca_pmt_reply() to the UDRD with the CA_enable flag set to 0x1. If the UDRD sends a ca_pmt with ca_pmt_cmd_id set to "ok_mmi", then note that the HPNX may send a ca_pmt_reply() to the UDRD with the CA_enable flag set to 0x1. Note: If UDRD send ca_pmt with ca_pmt_cmd_id set to "ok_mmi", then UDRD and HPNX may keep exchanging ca_pmt() and ca_pmt_reply().
23.	If the UDRD sends a ca_pmt with ca_pmt_cmd_id set to ok_descrambling, then the HPNX does not respond.
24.	If the UDRD sends a ca_pmt with program_info_length = 0 and no ca_pmt_cmd_id , then the HPNX does not respond.
25.	If the ca_pmt sent has ca_pmt_cmd_id set to one of the following "query or ok_mmi", then on the HPNX under the Conditional Access tab click the Stop button. Under the ca_pmt_reply settings expand the "ca_enable for program and elementary streams" pull down window. Select "Possible under conditions (technical dialogue)". Under the Conditional Access tab click the Play button. Note: This step is necessary to set up the HPNX ca_pmt_reply auto-response setting.
26.	Tune the UDRD to an scrambled or in-the-clear digital containing CA info channel and verify that the UDRD issues a ca_pmt() APDU to the HPNX
27.	If the UDRD sends a ca_pmt with ca_pmt_cmd_id set to "query", then note that the HPNX sends a ca_pmt_reply() to the UDRD with the CA_enable flag set to 0x1. If the UDRD sends a ca_pmt with ca_pmt_cmd_id set to "ok_mmi", then note that the HPNX may send a ca_pmt_reply() to the UDRD with the CA_enable flag set to 0x1. Note: If UDRD send ca_pmt with ca_pmt_cmd_id set to "ok_mmi", then UDRD and HPNX may keep exchanging ca_pmt() and ca_pmt_reply().
28.	If the UDRD sends a ca_pmt with ca_pmt_cmd_id set to ok_descrambling, then the HPNX does not respond.
29.	If the UDRD sends a ca_pmt with program_info_length = 0 and no ca_pmt_cmd_id , then the HPNX does not respond.

30.	<p>If the ca_pmt sent has ca_pmt_cmd_id set to one of the following “query or ok_mmi”, then on the HPNX under the Conditional Access tab click the Stop button. Under the ca_pmt_reply settings expand the “ca_enable for program and elementary streams” pull down window. Select “Not possible (because of no entitlement)”. Under the Conditional Access tab click the Play button.</p> <p>Note: This step is necessary to set up the HPNX ca_pmt_reply auto-response setting.</p>
31.	Tune the UDRD to a scrambled or in-the-clear digital channel containing CA info and verify that the UDRD issues a ca_pmt() APDU to the HPNX
32.	<p>If the UDRD sends a ca_pmt with ca_pmt_cmd_id set to “query”, then note that the HPNX sends a ca_pmt_reply() to the UDRD with the CA_enable flag set to 0x1.</p> <p>If the UDRD sends a ca_pmt with ca_pmt_cmd_id set to “ok_mmi”, then note that the HPNX may send a ca_pmt_reply() to the UDRD with the CA_enable flag set to 0x1.</p>
33.	If the UDRD sends a ca_pmt with ca_pmt_cmd_id set to ok_descrambling, then the HPNX does not respond.
34.	If the UDRD sends a ca_pmt with program_info_length = 0 and no ca_pmt_cmd_id , then the HPNX does not respond.
35.	<p>If the ca_pmt sent has ca_pmt_cmd_id set to one of the following “ query or ok_mmi”, then on the HPNX under the Conditional Access tab click the Stop button. Under the ca_pmt_reply settings expand the “ca_enable for program and elementary streams” pull down window. Select “Not possible (for technical reasons)”. Under the Conditional Access tab click the Play button.</p> <p>Note: This step is necessary to set up the HPNX ca_pmt_reply auto-response setting.</p>
36.	Tune the UDRD to a scrambled or in-the-clear digital channel containing CA info and verify that the UDRD issues a ca_pmt() APDU to the HPNX
37.	<p>If the UDRD sends a ca_pmt with ca_pmt_cmd_id set to “query”, then note that the HPNX sends a ca_pmt_reply() to the UDRD with the CA_enable flag set to 0x1.</p> <p>If the UDRD sends a ca_pmt with ca_pmt_cmd_id set to “ok_mmi”, then note that the HPNX may send a ca_pmt_reply() to the UDRD with the CA_enable flag set to 0x1.</p>
38.	If the UDRD sends a ca_pmt with ca_pmt_cmd_id set to ok_descrambling, then the HPNX does not respond.
39.	If the UDRD sends a ca_pmt with program_info_length = 0 and no ca_pmt_cmd_id , then the HPNX does not respond.
40.	<p>If the ca_pmt sent has ca_pmt_cmd_id set to one of the following “query or ok_mmi”, then on the HPNX under the Conditional Access tab click the Stop button. Under the ca_pmt_reply settings expand the “ca_enable for program and elementary streams” pull down window. Select “None”. Under the Conditional Access tab click the Play button.</p> <p>Note: This step is necessary to set up the HPNX ca_pmt_reply auto-response setting.</p>
41.	Tune the UDRD to a scrambled or in-the-clear digital channel containing CA info and verify that the UDRD issues a ca_pmt() APDU to the HPNX
42.	Using the HPNX expand the ca_update button and set the ca_enable to “Possible” and click Send.
43.	Verify that there are no transport timeouts, or other errors reported on the HPNX trace window.
44.	Using the HPNX expand the ca_update button and set the ca_enable to “Possible under conditions (purchase dialog)” and click Send.
45.	Verify that there are no transport timeouts, or other errors reported on the HPNX trace window.
46.	Using the HPNX expand the ca_update button and set the ca_enable to “Possible under conditions (technical dialog)” and click Send.
47.	Verify that there are no transport timeouts, or other errors reported on the HPNX trace window.

48.	Using the HPNX expand the ca_update button and set the ca_enable to "Not possible (because of no entitlement)" and click Send.
49.	Verify that there are no transport timeouts, or other errors reported on the HPNX trace window.
50.	Using the HPNX expand the ca_update button and set the ca_enable to "Not possible (for technical reasons)" and click Send.
51.	Verify that there are no transport timeouts, or other errors reported on the HPNX trace window.
52.	Right click on the Conditional Access session and select Add Session Slot, select the play button.
53.	Verify that the UDRD rejects the second Conditional Access session.
54.	Verify that the UDRD responds to the second open session request with an Open Session response with one of the following session status values. 0xF1 or 0xF3 as defined in EIA-679 page 71 Table 7.

Test Results: Host Conditional Access Resource Test

Measurement	Acceptable Result	Results	Comments
Verify successful establishment of application resource manager session DAPCa.1	HPNX Test Tool Trace		
Verify that the UDRD issues a CA_Info_Inquiry() to the POD tool DAPCa.5	HPNX Test Tool Trace		
Verify the UDRD does not open a second session to Conditional Access. DAPCa.2	HPNX Test Tool Trace		
Verify that the UDRD issues a ca_pmt() object to the POD tool. Verify that the syntax is correct DAPCa.7, DAPCa.10, DAPCa.11, DAPCa.12, DAPCa.22, CpsT.3	HPNX Test Tool Trace		

PICS Coverage for this Procedure

PICS Item	Quality
DAPCa.1	Direct
DAPCa.2	Direct
DAPCa.5	Direct
DAPCa.7	Direct
DAPCa.10	Direct
DAPCa.11	Direct
DAPCa.12	Indirect
DAPCa.22	Indirect
CpsT.3	Indirect

2.2.5 Host System Time Test

This test verifies that the Host supports a System Time resource.

Equipment: Host (UDRD), HPNX.

Procedure:

Step	Procedure
1.	Bring up the HPNX software on the given PC, and verify that the PC and HPNX are on the same isolated network.
2.	Under the Device tab, click on the name of the HPNX that you are working with.
3.	Select the "Pod Behavior mode" and click "connect", then, right click on the Trace window to select (at least) SPDU, TPDU and Payload for full vision of all layers.
4.	On the HPNX GUI click the Test tab. Select POD – "Low level test/ setup" window. In this window in the upper right hand corner click the Right arrow button to start the initialization process between the UDRD and the HPNX.
5.	Verify that the UDRD establishes a session to the Application Manager and reports support for System Time resource = 0x00240041.
6.	Select the "System Time" tab; press the Play button to open the System Time resource.
7.	Using the HPNX test tool, send a system_time_inq() with response interval = 1 second.
8.	Verify that the UDRD starts sending system_time() APDU to the HPNX at 1-second intervals.
9.	Using the HPNX test tool, send a system_time_inq() with response interval = 10 second.
10.	Verify that the UDRD starts sending system_time() object to the HPNX at 10-second intervals.
11.	After about 30 seconds, send a system_time_inq() with response interval equal to zero.
12.	Verify that the UDRD sends one final system_time() APDU.
13.	Right click on the System Time session and select Add session slot. Select the Play button.
14.	Verify that the UDRD denies a second system time session.

Test Results: Host System Time Test

Measurement	Acceptable Result	Results	Comments
Verify that the UDRD establishes a session to the Application Manager and reports support for System Time resource = 0x00240041 DApSt.8	HPNX Test Tool Trace		
Verify that the UDRD starts sending system_time() object to the POD at 10 second intervals DApSt.1, DApSt.2	HPNX Test Tool Trace		
Verify that the UDRD sends one final system_time() object DApSt.6	HPNX Test Tool Trace		
UDRD denies a second session request. DApSt.7	HPNX Test Tool Trace		

PICS Coverage for this Procedure













PICS Item	Quality
DApSt.1	Direct
DApSt.2	Direct
DApSt.6	Direct
DApSt.7	Direct
DApSt.8	Direct

2.2.6 Host MMI Test

This test verifies that the Host supports a Man Machine Interface Resource.

Equipment: Host (UDRD), HPNX , & Host Documentation Package submitted by vendor.

Procedure:

Step	Procedure
1.	Bring up the HPNX software on the given PC, and verify that the PC and HPNX are on the same isolated network.
2.	Under the Device tab, click on the name of the HPNX that you are working with.
3.	Select the "Pod Behavior mode" and click "connect", then, right click on the Trace window to select (at least) SPDU, TPDU and Payload for full vision of all layers.
4.	On the HPNX GUI click the Test tab. Select POD – "Low level test/ setup" window. In this window in the upper right hand corner click the Right arrow button to start the initialization process between the UDRD and the HPNX.
5.	Verify that the UDRD establishes a session to the Resource Manager and reports support for MMI resource = 0x00400081.
6.	Verify that the UDRD establishes a session to the Resource Manager and reports support for Application Information resource = 0x00020081.
7.	Go to the Application Information tab and click on it. Press the Play button to open the resource.
8.	Verify that the UDRD sends the application_info_req() APDU. Note the multi_window_support value within this APDU as it determines the UDRD display_type Write that here: _____
9.	Go to the Man Machine Interface tab and click on it. Press the Play button to open the resource.
10. i	Verify the UDRD successfully performs request/response of Resource 91 04 00 04 00 81.
11.	Verify these files are loaded on the given PC under C:/Program Files/Digital Keystone/Digital Keystone HPNX/Resources/test_files/mmi These files are required and contain html tags for mmi hyperlinks to pages. <div style="display: flex; justify-content: space-around; align-items: center;">      </div> mmi_ASCII_9.html mmi_ASCII_8.html mmi_ASCII_7.html mmi_ASCII_6.html mmi_ASCII_5.html <div style="display: flex; justify-content: space-around; align-items: center;">      </div> mmi_ASCII_4.html mmi_ASCII_3v2.htm mmi_ASCII_2v2.htm mmi_ASCII_1v2.htm mmi_ASCII_9.html <div style="display: flex; justify-content: space-around; align-items: center;">    </div> mmi_justify_blue.htr mmi16lines.html app_info_0v2.html

12.	Under the “Man Machine Interface” tab expand the open_mmi_req button and set the Display Type to what you recorded in step 8. Click the Browse button and select the URL, C:/Program Files/Digital Keystone/Digital Keystone HPNx/Resources/test_files/mmi_files/app_info_0v2.html. (Verify that the UDRD is on) Click Send, Verify that an opaque background comes up on the screen with white lettering stating “Application information (0) test page Digital Keystone”.
13.	From the HPNX trace window, note that the HPNX sends an APDU open_mmi_req to the UDRD. <-A open_mmi_req from Man Machine Interface
14.	From the HPNX trace window, verify that the Host replies with an open_mmi_cnf() APDU. >A open_mmi_cnf to Man Machine Interface
15.	For Link Navigation; On UDRD remote, press vendor displayed commands to navigate within the UDRD MMI displayed screen. Verify you can get through each link on UDRD. -Application Information (0) page with {Link} -mmi16lines by 32 character page with Fonts with {Link} & (optional Colors) -mmi_justify (Right, Center & Left) with {Link} -Complete ASCII Character Code with 8 {Links} and 9 html pages. ASCII characters on UDRD represent the ASCII characters defined in SCTE28 Table C.4-A; Characters and names are displayed from Numeric expression, Mnemonic expression (if applicable) and character name. Test script will display two characters in front of character name if a Mnemonic expression is listed in Table C.4-A.
16.	Press vendor displayed commands to exit the MMI display.
17.	Open the MMI display again. Click the Browse button and select the URL, C:/Program Files/Digital Keystone/Digital Keystone HPNx/Resources/test_files/mmi_files/app_info_0v2.html file again. Click Send, Verify that a opaque background comes up on the screen with white lettering stating “Application information (0) test page Digital Keystone”.
18.	From the HPNX trace window, note the dialog_number. You will need this dialog_number to perform a close mmi screen later in this test.
19.	Right click on the Man Machine Interface tab and select Add Session Slot. Click Play on the new session slot.
20.	Verify the UDRD sends an Open Session response to the Man Machine Interface, status = 0xF1 or 0xF3, session number = X. The UDRD should only support one MMI resource open at one time. Right click on the new session slot and select Delete Session Slot to close session.
21.	Expand the “+” (close_mmi_req) button. Input the dialog_number noted in step 18, and click Send.
22.	Verify that the Host closes the mmi page on the UDRD. Also verified in the trace window; UDRD responds with a close_mmi_cnf to Man Machine Interface.

Test Results: Host MMI Test

Measurement	Acceptable Result	Results	Comments
Verify that the UDRD establishes a session to the Application Manager and reports support for Man Machine Interface resource = 0x00040081, Application Info resource = 0x00020081 DapMi.1, DapAi.1	HPNX Test Tool Trace		

Measurement	Acceptable Result	Results	Comments
Open_status field correct DapMi.2, DapMi.4, DapMi.5, HPInit.240	Syntax correct		
Verify The Host issues a dialog_number from an eight-bit cyclic counter that identifies each open_mmi_cnf() APDU and allows the POD to close the MMI dialog. DapMi.6, DapAi.5	Dialog_number is:		
The Unidirectional Receiving Device MAY implement the following displays found in the display_type parameter: 0: Full screen 1: Overlay 2: Multiple window 3-F: Reserved DapMi.3, DapAi.7, DapAi.30, DapAi.31, DapAi.32	OPTIONAL: Check when MMI message is displayed on screen.		
Close first session DapMi.7, DapMi.10	Close_mmi_cnf() indicates that the right session was closed, syntax correct. Close_status is correct		
User Navigation DapMi.12, DapMi.13, DapMi.19, DapMi.24	User can navigate within the resource		
Html page sent to the Unidirectional Receiving Device. DapMi.11, DapMi.14, DapMi.15, DapMi.16, DapMi.18, DapMi.20, DapMi.25, DapMi.26, DapMi.31a, DapAi.33	Unidirectional Receiving Device continues to operate within normal operating parameters.		
The UDRD shall maintain the session open during normal operation DAPAi.13	HPNX read out		
Extract the current session of HPNX and select Application Info Script. The Host shall be capable of receiving the application_info_cnf() APDU. DAPAi.14	HPNX read out		
The Host shall send a server_query() APDU to the HPNX to request the information in the HPNX file server system pointed by a specific URL. DAPAi.15, DAPAi.16, DAPAi.17, DAPAi.18, DAPAi.21, DapAi.22	HPNX read out		

PICS Coverage for this Procedure

PICS Item	Quality
DapMi.1	Direct
DapMi.2	Direct

PICS Item	Quality
DapMi.3	Direct
DapMi.4	Direct
DapMi.5	Direct
DapMi.6	Direct
DapMi.7	Direct
DapMi.10	Direct
DapMi.11	Direct
DapMi.12	Direct
DapMi.13	Direct
DapMi.14	Direct
DapMi.15	Direct
DapMi.16	Direct
DapMi.18	Direct
DapMi.19	Direct
DapMi.20	Direct
DapMi.24	Direct
DapMi.25	Direct
DapMi.26	Direct
DapMi.31a	Direct
DAPAi.1	Direct
DAPAi.5	Direct
DAPAi.7	Direct
DAPAi.13	Direct
DAPAi.14	Direct
DAPAi.15	Direct
DAPAi.16	Direct
DAPAi.17	Direct
DAPAi.18	Direct
DAPAi.21	Direct
DAPAi.22	Direct
DAPAi.30	Direct
DAPAi.31	Direct
DAPAi.32	Direct
DAPAi.33	Direct
HPinit.240	Direct

2.2.7 Host Hot Insertion Test

This test verifies successful insertion and initialization of the POD in a host that is powered up and has finished its internal initialization. .

Equipment: Host under test, POD extender card (SYCARD PN# PCCextend 140A and PCCextend 145), logic analyzer (PN# Agilent 1672G), modified¹ logic analyzer pod adapter card (The modified card consists of installing Jumpers or wires between CD#1 pin 36, and JP2 pin F, and from CD2 Pin 67 to JP1 Pin A on the PCCcard 145 card).

Software: Logic Analyzer configuration file "HOST_44._A"

Setup: Connect host and HPNX to extender card PCCextend. Connect the modified logic analyzer pod adapter to the POD extender card and insert all 4 logic analyzer pods into the adapter.

SIGNALS MONITORED

Pin Number	Pin Name
36	CD1#, card detect 1
67	CD2#, card detect 2
7	CE1#, card enable 1
42	CE2#, card enable 2
16	READY
58	RESET
68	GND

Procedure:

Step	Procedure
1.	Apply power to UDRD test.
2.	Remove the HPNX extender from the UDRD.
3.	Insert the PCCextend 140A into the UDRD.
4.	Insert the HPNX extender into the other female end of the PCCextend 140A.
5.	Load file HOST_44._A into the logic analyzer. Power up the Agilent Logic Analyzer Model number 1672G. Click Analyzer, Select system. Click External I/O. Select hard disk. Scroll down until you find "HOST_44 ._A" Click Load, followed by Execute. This will load the analyzer configuration. (Results may vary depending on your Logic Analyzer.)
6.	Click System. Select analyzer. Click configuration and select Waveform Machine 1 option. Select "RUN" to initiate the capture process. (Once captured, the Times per division will need to be changed in order to see the following measurements.) (Results may vary depending on your Logic Analyzer.)
7.	On the HPNX click "Low level test set-up" Play button to start Initialization. The logic analyzer will trigger on the falling edge of CD2.
8.	Verify that RESET transitions from low to high, remains high for at least 10 usec before going low.
9.	Verify that READY transitions high within 5 seconds of RESET transitioning low. There should be no activity on the CE1# or CE2# pins until READY is high.

Example logic Analyzer Capture:

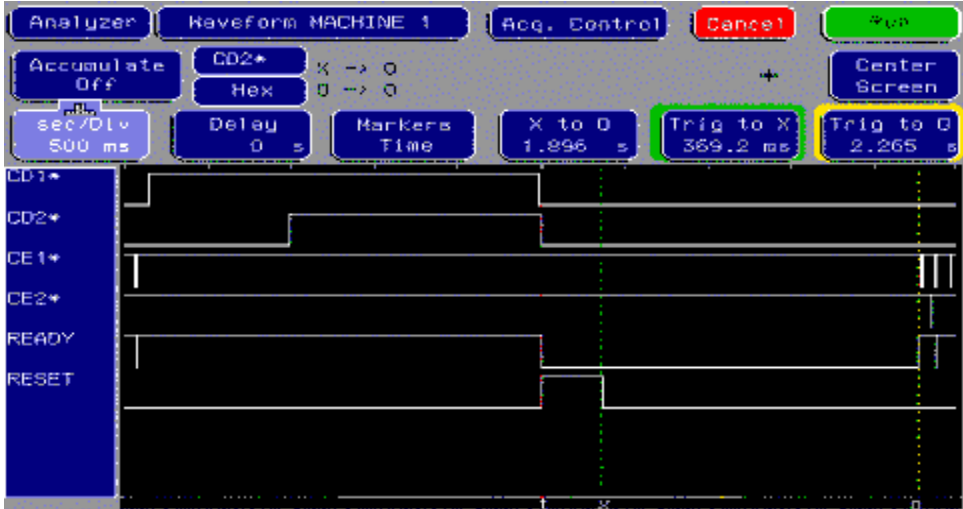

Test Results: Host Hot Insertion Test

Measurement	Acceptable Result	Results	Comments
Apply power to UDRD and tune to a digital service anywhere on the channel map verify television displays Video. Hpower.6	Host and POD recover and function properly		
Insert POD module; the television may present a message of POD insertion. The logic analyzer will trigger on the falling edge of CD2. Verify that RESET transitions from low to high, remains high for at least 10 usec before going low. HPPcs.2, HPPcs.3, HPPh.26	Minimum of 10 usec; occurs after CD1# and CD2# have gone low		
Verify that READY transitions high within 5 seconds of RESET transitioning low. There should be no activity on the CE1# or CE2# pins until READY is high. HPPcs.4, ExchP.1	No activity on CE1# and CE2# while READY low		

NOTE:1. The modified logic analyzer adapter card refers to the standard SYCARD PCCextend 145, which has been changed to allow access to signals CD1 and CD2.

PICS Coverage for this Procedure

PICS Item	Quality
Hpower.6	Direct
HPPcs.2	Direct
HPPcs.3	Indirect
HPPcs.4	Direct
HPPh.26	Indirect
ExchP.1	Direct

2.2.8 Host/POD PCS/OOB Test

This test verifies that the Host implements the Personality Change Sequence correctly.

Equipment: Host (UDRD), POD, HPNX, PCCextend 140A, logic analyzer, modified¹ logic analyzer pod adapter card, and oscilloscope.

Software: Logic Analyzer configuration file "HOST_46._A"

SIGNALS AVAILABLE

Pin Number	Pin Name
24	ITX
22	QTX
11	DRX
12	CRX
25	CTX
16	READY
48-50,53-56	MDI[0:7]
64-66, 37-41	MDO[0:7]

Setup: This test checks for transport stream activity. Connect the Host device to the headend. Turn the Host device on and tune it to a digital channel.

Procedure:

Step	Procedure
1.	Connect the HPNX to a PCCextend 140A and bring it to a stable operational state
2.	Insert in the PCCextend 140A in the PCMCIA port of the UDRD. Connect the modified logic analyzer pod adapter to the PCCextend 140A and insert all 4 logic analyzer pods into the adapter. Insert HPNX tool in to the PCCextend 140A.
3.	Load file HOST_46._A into the logic analyzer. Power up the Agilent Logic Analyzer Model number 1672G. Click Analyzer, Select system. Click External I/O. Select hard disk. Scroll down until you find "HOST_46._A" Click Load, followed by Execute. This will load the analyzer configuration.
4.	Change MENU from "SYSTEM" to "ANALYZER". Change display from "CONFIGURATION" to "WAVEFORM". Select "RUN" to initiate the capture process.
5.	On the HPNX click "Low level test set-up" Play button to start Initialization. The logic analyzer will trigger on the first rising edge of the READY signal after the RESET pulse.
6.	Verify that the UDRD does not route the MPEG data stream through the HPNX during PCMCIA reset (Observe on the logic analyzer that there is no activity on the MD pins during reset and Ready signal low).
7.	Verify personality change by observing on the logic analyzer that DRX has activity after the PCMCIA reset or that the MD pins are active.
8.	On the HPNX, select "Host Control" tab, click the Right arrow button to start the Host Control resource.

9.	<p>Verify from the HPNX test tool that the “open_session_request()”/“open_session_response()” transaction has completed as shown below.</p> <pre> ← S open_session_request from Host Control 91 04 00 20 00 43 → S open_session_response on resource Host Control, Status = 0x00, SessionNb = 2 92 07 00 00 20 00 43 00 02 </pre>
10.	<p>Using the HPNX test tool, expand the OOB_RX_Tune_req button and send oob_rx_tune() requests with the following parameter values, and verify that the UDRD replies with an oob_rx_tune_cnf() with “tuning granted”.</p> <p>Frequency= 75250 KHz bit rate = 2048 kbps Spectrum = 0 (non-inv)</p>
11.	<p>Measure the set-up time (Tsu) of DRX with respect to rising edge of CRX. Tsu is defined as the time from where; DRX reaches 90% of the high level (rising), or 10% of high level (falling) to where CRX reaches 50% of its high level. Measure both rising and falling times.</p>
12.	<p>Measure the hold time (t_H) of DRX with respect to rising edge of CRX. The hold time is the time from when CRX reaches 50% of the high level to when DRX reaches 90% of the high level (falling) or 10% of the high level (rising). Measure both rising and falling hold times.</p>

Note: Tester may choice to use an Oscilloscope to measure both the set-up time (Tsu) of DRX with respect to rising edge of CRX and the hold time of DRX with respect to rising edge of CRX.

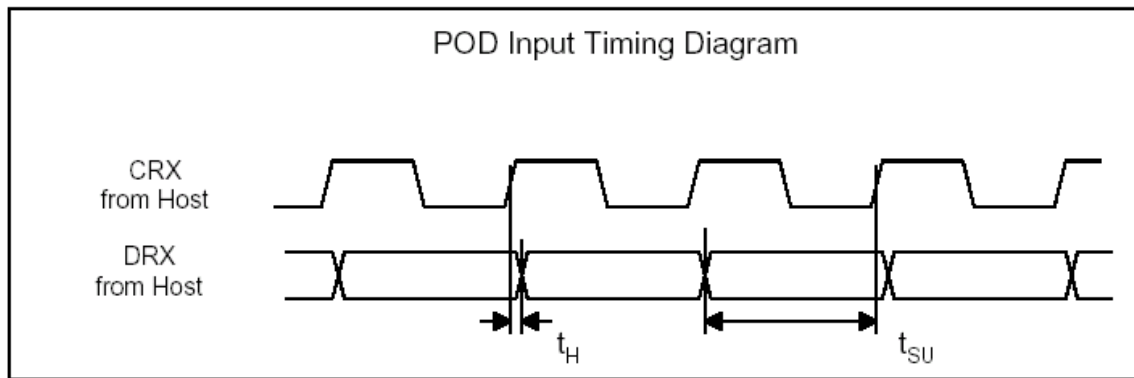

Test Results: Host/POD PCS/ OOB Test

Measurement	Acceptable Result	Results	Comments
OOB interface connected to POD emulator HPPii.9,	Activity on A9:A4 pins		
MPEG data not routed through POD during reset HPPii.2, HPPii.11	No activity on the MD pins while Ready signal low		
Set-Up Time – rising & falling Procedure 2 FDCP.11	Tsu ≥ 10ns		
Hold Time – rising & falling Procedure 2 FDCP.12	Th ≥ 5ns		

PICS Coverage for this Procedure

PICS Item	Quality
HPPii.2	Direct
HPPii.9	Direct
HPPii.11	Direct
FDCP.11	Direct
FDCP.12	Direct

2.2.9 Host Standby Mode Test

This test verifies the operation of the Host in Standby Mode.

Equipment: Host under test, HPNX, POD extender card SYCARD PCCextend 140A, logic analyzer and modified¹ logic analyzer pod adapter card SYCARD PCCextend 145.

Software: Logic Analyzer configuration file "HOST_437._A"

Setup: Connect Host to POD extender card, HPNX to extender card. Connect the modified logic analyzer pod adapter to the POD extender card and insert all 4 logic analyzer pods into the adapter.

SIGNALS MONITORED

Pin Number	Pin Name
12	CRX
11	DRX

Procedure:

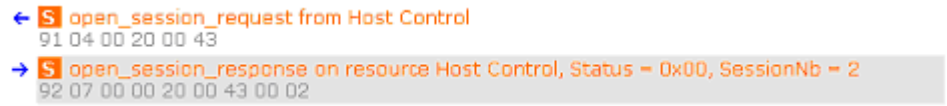
Step	Procedure
1.	Bring up the HPNX software on the given PC, and verify that the PC and HPNX are on the same isolated network.
2.	Under the Device tab, click on the name of the HPNX that you are working with.
3.	Select the "Pod Behavior mode" and click "connect", then, right click on the Trace window to select (at least) SPDU, TPDU and Payload for full vision of all layers.
4.	On the HPNX GUI click the Test tab. Select POD – "Low level test/ setup" window. In this window in the upper right hand corner click the Right arrow button to start the initialization process between the UDRD and the HPNX.
5.	Select "Host Control" tab, click the Right arrow button to start the Host Control resource.
6.	Verify from the HPNX test tool that the "open_session_request()"/"open_session_response()" transaction has completed as shown below. 
7.	Using the HPNX test tool, expand the OOB_RX_Tune_req button and send oob_rx_tune() requests with the following parameter values, and verify that the UDRD replies with an oob_rx_tune_cnf() with "tuning granted". Frequency= 75250 KHz bit rate = 2048 kbps Spectrum = 0 (non-inv)

8.	Load file HOST_437._A into the logic analyzer. Power up the Agilent Logic Analyzer Model number 1672G. Click Analyzer, Select system. Click External I/O and select hard disk. Scroll down until you find "HOST_437._A" Click Load, followed by Execute. This will load the analyzer configuration.
9.	Insert in the PCCextend 140A in the PCMCIA port of the UDRD. Connect the modified logic analyzer pod adapter to the PCCextend 140A and insert all 4 logic analyzer pods into the adapter. Insert HPNX tool in to the PCCextend 140A.
10.	Load file HOST_437._A into the logic analyzer. Change MENU from "SYSTEM" to "ANALYZER". Change display from "CONFIGURATION" to "WAVEFORM". Select "RUN" ("Select "Repetitive") to initiate the capture process. The analyzer will trigger continuously on the rising edge of CRX . Verify that the clock signal, CRX , is present as well as DRX.
11.	Put the Host in standby mode by pressing the power button on the front panel.
12.	Verify that there is no change to any of the signals.

Test Results: Host Standby Mode Test

Measurement	Acceptable Result	Results	Comments
OOB receive circuitry powered Hpower.9	After the HPNX is initialized, OOB interface signals remain powered when power turned off at front panel switch.		

Example logic Analyzer Capture:

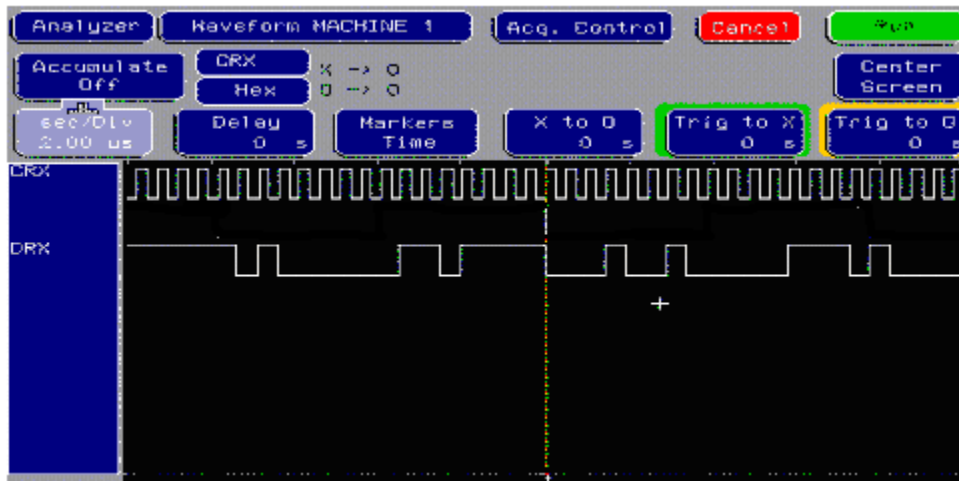

PICS Coverage for this Procedure

PICS Item	Quality
Hpower.9	Direct

Note: The modified logic analyzer adapter card refers to the standard SYCARD PCCextend, 145 which have been changed to allow access to signals CD1 and CD2. Rework as follows: CD1 connect to JP2 pin F, CD2 connect to JP1 pin A.

2.2.10 Host Extended Channel Test

This test verifies that the Host can successfully implement link layer protocols for extended channel. The test also verifies that the Host opens a flow of type MPEG sections.

Equipment: Host (UDRD), HPNX Test tool.

Procedure:

Step	Procedure
1.	Bring up the HPNX software on the given PC, and verify that the PC and HPNX are on the same isolated network.
2.	Under the Device tab, click on the name of the HPNX that you are working with.
3.	Select the "Pod Behavior mode" and click "connect", then, right click on the Trace window to select (at least) SPDU, TPDU and Payload for full vision of all layers.
4.	On the HPNX GUI click the Test tab. Select POD – "Low level test/ setup" window. In this window in the upper right hand corner click the Right arrow button to start the initialization process between the UDRD and the HPNX.
5.	Press Play button on the POD- Low-level test/setup.
6.	Verify successful completion of the data channel and the extended data channel initialization. To do this verifies that the HPNX and UDRD have successfully negotiated the buffer size for both data and extended channel. Example: <ul style="list-style-type: none"> → H Buffer Size (128 bytes) has been written on DATA channel → H Set SR on EXTENDED ← H Buffer (128 bytes) Size has been read on EXTENDED channel → H Set SW on EXTENDED → H Buffer Size (128 bytes) has been written on EXTENDED channel
7.	Expand the "Extended Channel" tab, depending on the UDRD you may have to change the resource version of the HPNX to match that of the UDRD. Right click on the Session slot. Select "Change Resource Version". Enter the correct resource version needed to match the UDRD (version 1 or version 2 as defined in SCTE 28 section 8.9). Click OK. On the "Extended channel" tab press the Play button to open the extended channel resource.
8.	Verify that the UDRD sends a new_flow_req() with service_type = MPEG_section. (PID = 0x1FFC).
9.	Note that the HPNX Test tool sends back new_flow_cnf() granting the flow. Note: the Flow_Id (0x_____)
10.	Using the HPNX Test tool, click on the lost_flow_ind button and enter the flow_id recorded in step 9. In the pull down window select "unknown or unspecified reason" and click Send to send a lost_flow_ind() to the UDRD.
11.	Verify that the UDRD acknowledges the lost_flow_ind by sending a lost_flow_cnf() APDU.
12.	Extract current HPNX by clicking the Low Level Test/Set up tab and close the session. Expand the Physical button and change the Max Buffer size to 16 for data and extended channels. Click the Play button. Verify from the trace window that the buffer size negotiation results in 16 bytes for both the data channel and the extended channel. Also, click on the State tab to view the Buffer Size. Expand Low Level State, then expand Buffer Size.

13.	<p>Right click on the Extended Channel tab. Select "Change Resource Version". In the Explorer User Prompt window, change the version to one (1). Click OK. On the Extended Channel tab, press the Play button. Expand the Flow Feed button. Click Browse. Select "Moto_STT.hex". Click Open. Under Extended Channel Flow Feed, enter one (1) for "Flow Id". Click Send.</p> <div style="text-align: center;">  Moto_STT.hex </div> <p>Verify the HPNX splits the data field of a TPDU into several blocks of smaller sizes. What needs to be observed here is that the HPNX will break a large message into as many parts as necessary to get the message across the interface to the UDRD.</p>
-----	---

Test Results: Host Extended Channel Link Layer Test

Measurement	Acceptable Result	Results	Comments
Verify successful completion data channel and extended data channel initialization ExchF.1, ExchF.24, ExchL.5, ExchL.6	HPNX read out		
Verify that the UDRD sends a new_flow_req() with service_type = MPEG_section. (PID = 0x1FFC) ExchL.1, ExchL.2, ExchF.2, ExchF.4, ExchF.28, ExchF.30	HPNX read out		
Verify that the UDRD has started receiving data on PID 0x1FFC ExchF.36	HPNX read out		
Verify that the UDRD acknowledges by sending a lost_flow_cnf() PDU ExchL.7, ExchF.11	HPNX read out		
Verify Responds to Lost_flow_ind() with a Lost_flow_cnf() APDU with corresponding FLOW_ID value and Status_field = 0x00 (Ack) NOTE: This requirement exists in SCTE 28, but no PICS items exist for this requirement.	HPNX read out	NA	NA

PICS Coverage for this Procedure

PICS Item	Quality
ExchL.1	Direct
ExchL.2	Indirect
ExchL.5	InDirect
ExchL.6	InDirect
ExchL.7	Direct
ExchF.1	Direct
ExchF.2	Direct
ExchF.4	Direct
ExchF.11	Direct
ExchF.24	Direct
ExchF.28	Direct
ExchF.30	Direct
ExchF.36	Indirect

2.2.11 Virtual Channel Number Processing

Introduction: This test verifies different profiles of SI tables delivered via an out-of-band path to support service selection and navigation by digital cable set-top boxes and other “digital cable-ready” devices. The SI tables defined in this test procedure are formatted in accordance with SCTE 65.

Equipment: Host under test (UDRD), monitor, HPNX Test tool and OOB files (Profile1.hex, Profile2thru3.hex, Profile 4.hex, Profile 5.hex, Motorola Channel Map.xls (see step 10)).

Note: The attached files need to be copied to the computer running the HPNX application,



Profile1.hex



profile2thru3.hex



Profile4.hex



Profile5.hex

Procedure:

Step	Procedure
1.	Bring up the HPNX software on the given PC, and verify that the PC and HPNX are on the same isolated network.
2.	Under the Device tab, click on the name of the HPNX that you are working with.
3.	Select the “Pod Behavior mode” and click “connect”, then, right click on the Trace window to select (at least) SPDU, TPDU and Payload for full vision of all layers.
4.	On the HPNX GUI click the Test tab. Select POD – “Low level test/ setup” window. In this window in the upper right hand corner click the Right arrow button to start the initialization process between the UDRD and the HPNX.
5.	Press Play button on the POD- Low level test/setup.
6.	Expand the “Extended Channel” tab, depending on the UDRD you may have to change the resource version of the HPNX to match that of the UDRD. Right click on the Session slot. Select “Change Resource Version”. Enter the correct resource version needed to match the UDRD (version 1 or version 2 as defined in SCTE 28 section 8.9). Click OK. On the “Extended channel” tab press the Play button to open the extended channel resource.

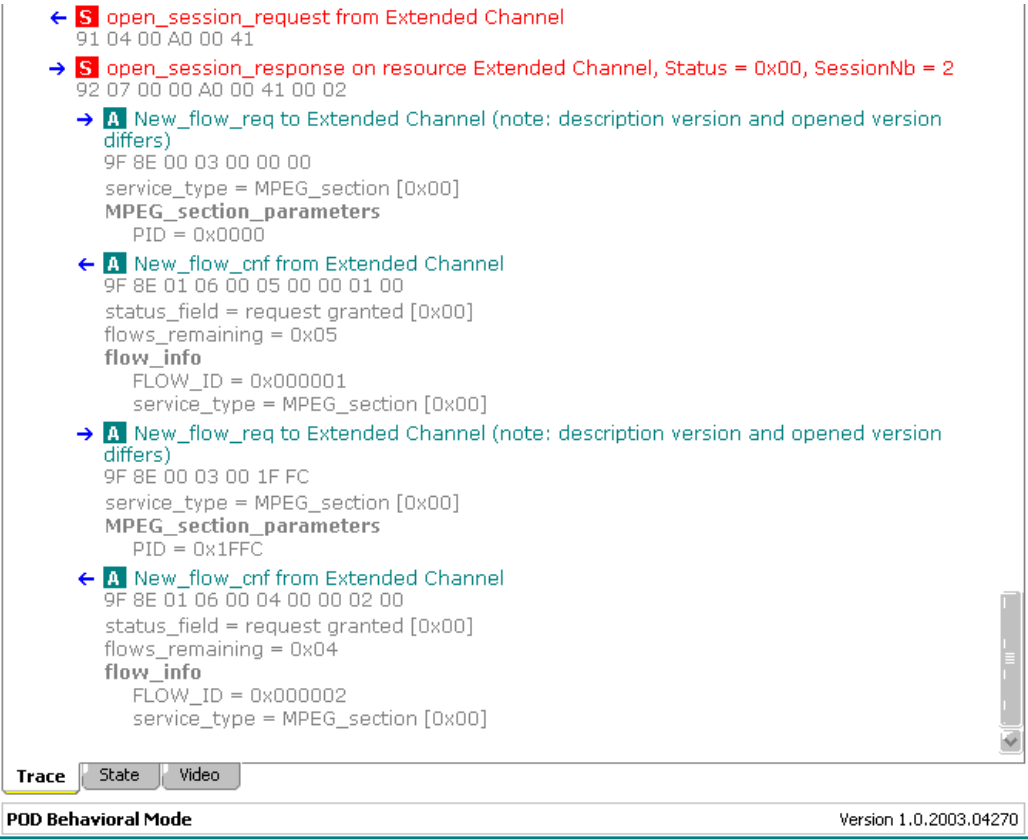
7.	<p>Verify that the UDRD issues a <code>New_flow_req</code> to Extended Channel requesting a <code>service_type = MPEG_section</code> with a <code>PID = 0x1FFC</code>. See example below.</p>  <p>The screenshot shows a network trace with the following messages:</p> <ul style="list-style-type: none"> S open_session_request from Extended Channel: 91 04 00 A0 00 41 S open_session_response on resource Extended Channel, Status = 0x00, SessionNb = 2: 92 07 00 00 A0 00 41 00 02 A New_flow_req to Extended Channel (note: description version and opened version differs): 9F 8E 00 03 00 00 00 service_type = MPEG_section [0x00] MPEG_section_parameters PID = 0x0000 A New_flow_cnf from Extended Channel: 9F 8E 01 06 00 05 00 00 01 00 status_field = request granted [0x00] flows_remaining = 0x05 flow_info FLOW_ID = 0x000001 service_type = MPEG_section [0x00] A New_flow_req to Extended Channel (note: description version and opened version differs): 9F 8E 00 03 00 00 1F FC service_type = MPEG_section [0x00] MPEG_section_parameters PID = 0x1FFC A New_flow_cnf from Extended Channel: 9F 8E 01 06 00 04 00 00 02 00 status_field = request granted [0x00] flows_remaining = 0x04 flow_info FLOW_ID = 0x000002 service_type = MPEG_section [0x00] <p>At the bottom of the screenshot, there are tabs for 'Trace', 'State', and 'Video'. Below the trace is a header 'POD Behavioral Mode' and 'Version 1.0.2003.04270'.</p> <p>Please note the FLOW_ID assigned by the UDRD in the <code>New_flow_cnf</code>.</p> <p>In this example the FLOW_ID assigned to the PID 0x1FFC MPEG_section flow is 0x000002.</p>
8.	<p>In the "Extended channel" tab, under the "Flow Feed" function. Next to the "SI table file" click the Browse button. Select the "Profile1.hex" file from wherever you have stored it on the HPNX, and click "OPEN".</p>
9.	<p>Enter the FLOW_ID that was noted in step 7 into the Flow ID window and click Send.</p> <p>NOTE: It is imperative that the correct Flow id be used in order for this test to function properly.</p> <p>FYI: In this step immediately after you click send, the following tables will be sent to the UDRD.</p> <ol style="list-style-type: none"> 2.) Network Information Table with a Carrier Definition table subtype. 3.) Network Information Table with a Modulation Mode table subtype 1. 4.) Network Information Table with a Modulation Mode table subtype 2. 5.) Short Form Virtual Channel Table with a Defined Channel Map subtype. 6.) Short Form Virtual Channel Table with a Virtual Channel Map subtype 1. 7.) Short Form Virtual Channel Table with a Virtual Channel Map subtype 2. 8.) Short Form Virtual Channel Table with a Virtual Channel Map subtype 3. 9.) System Time Table. 10.) Network Text Table with a Source Name Sub-table subtype.

10.	<p>On the UDRD using the channel up and down buttons or the remote control, verify that the channel map has been successfully loaded and that the UDRD can navigate the channel map. Attached is the channel map that is used for this test.</p>  <p>"Motorola Channel Map.xls"</p>
11.	<p>Using whatever means available, clear the channel map from the UDRD. Example of this would be on a Motorola UDRD press and hold the "Power" and "select" buttons on the front panel. While depressing these buttons unplug the UDRD and allow the front panel to flash at least 3 times and release the buttons. Power on the UDRD and verify that there is no channel map loaded. This can be accomplished by channel up down operations.</p>
12.	<p>Repeat steps 1 through 7.</p>
13.	<p>In the "Extended channel" tab, under the "Flow Feed" function. Next to the "SI table file" click the Browse button. Select the "Profile2thru3.hex" file from wherever you have stored it on the HPNX, and click "OPEN".</p>
14.	<p>Enter the FLOW_ID that was noted in step 7 into the Flow ID window and click Send.</p> <p>NOTE: It is imperative that the correct Flow id be used in order for this test to function properly.</p> <p>FYI: In this step immediately after you click send, the following tables will be sent to the UDRD.</p> <ol style="list-style-type: none"> 1.) Network Information Table with a Carrier Definition table subtype. 2.) Network Information Table with a Modulation Mode table subtype 1. 3.) Network Information Table with a Modulation Mode table subtype 2. 4.) Short Form Virtual Channel Table with a Defined Channel Map subtype. 5.) Short Form Virtual Channel Table with a Virtual Channel Map subtype 1. 6.) Short Form Virtual Channel Table with a Virtual Channel Map subtype 2. 7.) Short Form Virtual Channel Table with a Virtual Channel Map subtype 3. 8.) System Time Table. 9.) Network Text Table with a Source Name Sub-table subtype.
15.	<p>On the UDRD using the channel up and down buttons or the remote control, verify that the channel map has been successfully loaded and that the UDRD can navigate the channel map. See step 10 for the channel map that is used for this test.</p>
16.	<p>Using whatever means available clear the channel map from the UDRD.</p>
17.	<p>Repeat steps 1 through 7.</p>
18.	<p>In the "Extended channel" tab, under the "Flow Feed" function. Next to the "SI table file" click the Browse button. Select the "Profile4.hex" file from wherever you have stored it on the HPNX, and click "OPEN".</p>

19.	<p>Enter the FLOW_ID that was noted in step 7 into the Flow ID window and click send. NOTE: It is imperative that the correct Flow id be used in order for this test to function properly.</p> <p>FYI: In this step immediately after you click send, the following tables will be sent to the UDRD.</p> <ol style="list-style-type: none"> 1.) Network Information Table with a Carrier Definition table subtype. 2.) Network Information Table with a Modulation Mode table subtype 1. 3.) Network Information Table with a Modulation Mode table subtype 2. 4.) Short Form Virtual Channel Table with a Defined Channel Map subtype. 5.) Short Form Virtual Channel Table with a Virtual Channel Map subtype 1. 6.) Short Form Virtual Channel Table with a Virtual Channel Map subtype 2. 7.) Short Form Virtual Channel Table with a Virtual Channel Map subtype 3. 8.) System Time Table. 9.) Network Text Table with a Source Name Sub-table subtype. 10.) Master Guide Table.
20.	<p>On the UDRD using the channel up and down buttons or the remote control, verify that the channel map has been successfully loaded and that the UDRD can navigate the channel map. See step 10 for the channel map that is used for this test.</p>
21.	<p>Using whatever means available clear the channel map from the UDRD.</p>
22.	<p>Repeat steps 1 through 7.</p>
23.	<p>In the "Extended channel " tab, under the "Flow Feed" function. Next to the "SI table file" click the Browse button. Select the "Profile5.hex" file from wherever you have stored it on the HPNX, and click "OPEN".</p>
24.	<p>Enter the FLOW_ID that was noted in step 7 into the Flow ID window and click send. NOTE: It is imperative that the correct Flow id be used in order for this test to function properly.</p> <p>FYI: In this step immediately after you click send, the following tables will be sent to the UDRD.</p> <ol style="list-style-type: none"> 11.) Network Information Table with a Carrier Definition table subtype. 12.) Network Information Table with a Modulation Mode table subtype 1. 13.) Network Information Table with a Modulation Mode table subtype 2. 14.) Short Form Virtual Channel Table with a Defined Channel Map subtype. 15.) Short Form Virtual Channel Table with a Virtual Channel Map subtype 1. 16.) Short Form Virtual Channel Table with a Virtual Channel Map subtype 2. 17.) Short Form Virtual Channel Table with a Virtual Channel Map subtype 3. 18.) System Time Table. 19.) Network Text Table with a Source Name Sub-table subtype. 20.) Master Guide Table. 21.) Aggregate Event Information Table
25.	<p>On the UDRD using the channel up and down buttons or the remote control, verify that the channel map has been successfully loaded and that the UDRD can navigate the channel map. See step 10 for the channel map that is used for this test.</p>

Test Results: Virtual Channel Number Processing

Measurement	Acceptable Result	Results	Comments
Use channel up or down to navigate the channel map. VirtChan.1	In each case, the Host can navigate the channel map.		

PICS Coverage for this Procedure

PICS Item	Quality
VirtChan.1	Direct

2.2.12 In band Host Control and Host POD Firmware Upgrade Test (Homing)

This test verifies that the Host can support firmware upgrade of a POD inserted in it.

Equipment: Host (UDRD), HPNX Test tool, and OOB file (Profile1.hex).

Procedure:

Step	Procedure
1.	Bring up the HPNX software on the given PC, and verify that the PC and HPNX are on the same isolated network.
2.	Under the Device tab, click on the name of the HPNX that you are working with.
3.	Select the "Pod Behavior mode" and click "connect", then, right click on the Trace window to select (at least) SPDU, TPDU and Payload for full vision of all layers.
4.	On the HPNX GUI click the Test tab. Select POD – "Low level test/ setup" window. In this window in the upper right hand corner click the Right arrow button to start the initialization process between the UDRD and the HPNX.
5.	Press the Play button on the POD-Low level test/setup tab.
6.	Using the HPNX Test Tool trace, verify that the UDRD supports the Homing resource with ID 0x00110042.
7.	Expand the "Extended Channel" tab, depending on the UDRD you may have to change the resource version of the HPNX to match that of the UDRD. Right click on the Session slot. Select "Change Resource Version". Enter the correct resource version needed to match the UDRD (version 1 or version 2 as defined in SCTE 28 section 8.9). Click OK. On the "Extended channel" tab press the Play button to open the extended channel resource.

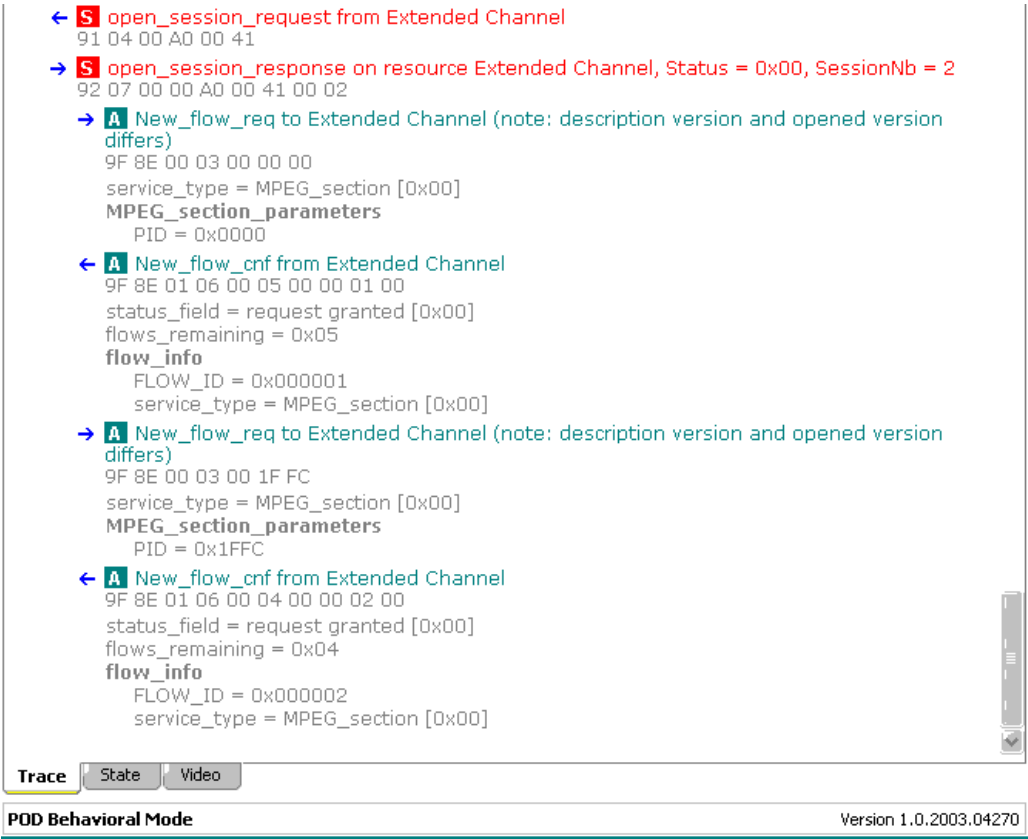
<p>8.</p>	<p>Verify that the UDRD issues a <code>New_flow_req</code> to Extended Channel requesting a <code>service_type = MPEG_section</code> with a <code>PID = 0x1FFC</code>. See example below.</p>  <p>Please note the <code>FLOW_ID</code> assigned by the UDRD in the <code>New_flow_cnf</code>.</p> <p>In this example the <code>FLOW_ID</code> assigned to the <code>PID 0x1FFC MPEG_section</code> flow is <code>0x000002</code>.</p>
<p>9.</p>	<p>In the “Extended channel” tab, expand the “Flow Feed” button. Next to the “SI table file” click the Browse button. Select the “Profile1.hex” file from wherever you have stored it on the HPNX, and click “OPEN”.</p>
<p>10.</p>	<p>Enter the <code>FLOW_ID</code> that was noted above, into the Flow ID window and click Send.</p> <p>NOTE: It is imperative that the correct <code>FLOW_ID</code> be used in order for this test to function properly.</p> <p>FYI: In this step immediately after you click Send, the following tables will be sent to the UDRD.</p> <ol style="list-style-type: none"> 1. Network Information Table with a Carrier Definition table subtype. 2. Network Information Table with a Modulation Mode table subtype 1. 3. Network Information Table with a Modulation Mode table subtype 2. 4. Short Form Virtual Channel Table with a Defined Channel Map subtype. 5. Short Form Virtual Channel Table with a Virtual Channel Map subtype 1. 6. Short Form Virtual Channel Table with a Virtual Channel Map subtype 2. 7. Short Form Virtual Channel Table with a Virtual Channel Map subtype 3. 8. System Time Table. 9. Network Text Table with a Source Name Sub-table subtype.
<p>11.</p>	<p>On the “Homing” tab press the Play button to open the Homing resource.</p>

12.	Bring the UDRD to a "STANDBY" state by pressing the power button so that the UDRD appears to be in an "off" state.
13.	<p>Verify that the HPNX Test tool received an open_homing() APDU from the UDRD.</p> <pre> ← S open_session_request from Homing 91 04 00 11 00 42 → S open_session_response on resource Homing, Status = 0x00, SessionNb = 2 92 07 00 00 11 00 42 00 02 → S session_number (incoming APDU) on Session Nb 2 (Homing) 90 02 00 02 9F 99 90 00 → A open_homing to Homing 9F 99 90 00 ← A open_homing_reply from Homing 9F 99 92 00 ← S session_number on Session Nb 2 (Homing) 90 02 00 02 9F 99 92 00 → S session_number (incoming APDU) on Session Nb 2 (Homing) 90 02 00 02 9F 99 93 00 → A homing_active to Homing 9F 99 93 00 </pre>
14.	Bring the UDRD out of the "STANDBY" state by pressing the power button so that the UDRD appears to be in an "on" state.
15.	Verify that the HPNX Test tool received a homing_cancelled() APDU from the UDRD.
16.	<p>Under the "Homing" tab expand the firmware_upgrade button and set the following parameter values:</p> <ul style="list-style-type: none"> upgrade source = QAM In Band Channel Download time = 0 seconds timeout type = No Timeout download_timeout_period = 0 seconds user notification text = "Performing download test" <p>Click Send to issue the firmware_upgrade() APDU to the UDRD.</p> <p>Note: It may be necessary to repeat steps 4 and 5 at this point.</p>
17.	Verify that the HPNX Test tool received a firmware_upgrade_reply() APDU from the UDRD.
18.	Verify that the UDRD displays message "Performing download test."
19.	Select the "Host Control" tab; press the Play button to open the Host Control resource.

20.	<p>Using the HPNX test tool, send <code>inband_tune_req()</code> requests with the following parameter values, and verify that the UDRD replies with an <code>inband_tuning_cnf()</code> with tuning accepted.</p> <p>Frequency Tune type = Frequency, Low Frequency , Modulation type = 64QAM (Use such as the lowest digital channel frequency that is present on the CableLabs plant).</p> <p>Tune type = Frequency, High Frequency, , Modulation type = 256QAM (Use such as the highest digital channel frequency that is present on the CableLabs plant).</p> <p>Source ID Tune type = Source ID, Source ID = 7795 NOTE: This Source ID is set in the channel map that was previously sent.</p>
21.	<p>Under the "Homing" tab expand the <code>firmware_upgrade_complete</code> button and set the <code>reset_request_status</code> to "No reset requested." Click Send to issue the <code>firmware_upgrade_complete()</code> APDU to the UDRD.</p>
22.	<p>Verify that the UDRD no longer displays the user notification text and continues normal operation without performing a reset on the POD.</p>
23.	<p>Verify that the UDRD can now take control of the tuner by attempting to change the channel.</p>
24.	<p>Under the "Homing" tab expand the <code>firmware_upgrade</code> button and set the following parameter values:</p> <p style="padding-left: 40px;"> <code>upgrade source = QAM In Band Channel</code> <code>Download time = 0 seconds</code> <code>timeout type = Both Timeouts</code> <code>download_timeout_period = 10 seconds</code> <code>user notification text = "Performing download test"</code> </p> <p>Click Send to issue the <code>firmware_upgrade()</code> APDU to the UDRD.</p>
25.	<p>Verify that the HPNX Test tool received a <code>firmware_upgrade_reply()</code> APDU from the UDRD.</p>
26.	<p>Repeat the previous two steps (click the Send button) every 5 seconds, at least 4 times. Verify that the UDRD does NOT reset the HPNX (because each <code>firmware_upgrade()</code> APDU extends the timeout by 10 seconds).</p>
27.	<p>Verify that the UDRD performs a PCMCIA reset of the POD 10 seconds after sending the last <code>firmware_upgrade()</code> (because the UDRD did not receive a <code>firmware_upgrade_complete()</code> APDU). (A PCMCIA reset begins in the Trace window with the words: [H] RESET asserted on the PCCARD interface.)</p>
28.	<p>Wait for the reset and POD initialization to complete.</p>
29.	<p>On the "Homing" tab press the Play button to open the Homing resource.</p>
30.	<p>Under the "Homing" tab expand the <code>firmware_upgrade</code> button and set the following parameter values:</p> <p style="padding-left: 40px;"> <code>upgrade source = QAM In Band Channel</code> <code>Download time = 0 seconds</code> <code>timeout type = Both Timeouts</code> <code>download_timeout_period = 0 seconds</code> <code>user notification text = "Performing download test"</code> </p> <p>Click Send to issue the <code>firmware_upgrade()</code> APDU to the UDRD.</p>
31.	<p>Verify that the HPNX Test tool received a <code>firmware_upgrade_reply()</code> APDU from the UDRD.</p>

32.	Wait at least 60 seconds. Verify that the UDRD does NOT reset the HPNX (because a download_timeout_period of 0 is an indefinitely long timeout).
33.	Under the "Homing" tab expand the firmware_upgrade_complete button and set the reset_request_status to "PCMCIA reset request." Click Send to issue the firmware_upgrade_complete() APDU to the UDRD.
34.	Verify that the UDRD performs a PCMCIA reset of the POD. (A PCMCIA reset beings in the Trace window with the words: [H] RESET asserted on the PCCARD interface.)
35.	Wait for the reset and POD initialization to complete.
36.	On the "Homing" tab press the Play button to open the Homing resource.
37.	Under the "Homing" tab expand the firmware_upgrade button and set the following parameter values: upgrade source = QAM In Band Channel Download time = 0 seconds timeout type = Both Timeouts download_timeout_period = 0 seconds user notification text = "Performing download test" Click send to issue the firmware_upgrade() APDU to the UDRD.
38.	Verify that the HPNX Test tool received a firmware_upgrade_reply() APDU from the UDRD.
39.	Under the "Homing" tab expand the firmware_upgrade_complete button and set the reset_request_status to "POD reset." Click send to issue the firmware_upgrade_complete() APDU to the UDRD.
40.	Verify that the UDRD performs a POD reset of the POD. (A PCMCIA reset beings in the Trace window with the words: [H] Set RS on DATA.)
41.	Wait for the reset and POD initialization to complete.
42.	Select the "Homing Control" tab; press the Play button to open the Homing Control resource.
43.	Under the "Homing" tab expand the firmware_upgrade button and set the following parameter values: upgrade source = QAM In Band Channel Download time = 0 seconds timeout type = Both Timeouts download_timeout_period = 0 seconds user notification text = "Performing download test" Click Send to issue the firmware_upgrade() APDU to the UDRD.
44.	Select the "Host Control" tab; press the Play button to open the Host Control resource.
45.	Using the HPNX test tool, send inband_tune_req() requests with the following parameter values, and verify that the UDRD replies with an inband_tuning_cnf() with tuning accepted. Source ID Tune type = Source ID, Source ID = 12017 (UDRD DISPLAYS HBO West; ch 195) NOTE: This Source ID is set in the channel map that was previously sent.
46.	Click on the "VIDEO" tab from the trace window at the bottom top of the screen. Click the pull down menu and select Host Capture under Transport Stream Route. In the Program Number box below the black screen type in the correct program number. Enter "3" which is for Hits 10 program number for channel 195. (reference: Cablelabs Motorola Channel Map). Click Start Render. Verify the video on the HPNX screen is HITS 10 HBO West channel 195 (Reference Cablelabs Motorola Channel Map.)

47.	Under the “Homing” tab expand the firmware_upgrade_complete button and set the reset_request_status to “No reset requested.” Click send to issue the firmware_upgrade_complete() APDU to the UDRD.
-----	--

Test Results: Host POD Firmware Upgrade Test

Measurement	Acceptable Result	Results	Comments
Verify that the UDRD supports the Homing resource with ID 0x00110042. DApHm.1, DApHm.2	HPNX test log		
Verify that the UDRD sent an open_homing() APDU when entering STANDBY. DapHm.2a, DApHm.4, DApHm.5, DAPHm.8, DAPHm.9	HPNX test log		
Verify that the UDRD sent a homing_cancelled() when the UDRD exited STANDBY, if the UDRD did not yet receive a firmware_upgrade(). DapHm.10, DapHm.11	HPNX test log		
Verify that the UDRD sends a firmware_upgrade_reply() in response to the firmware_upgrade(). DApHm.23, DApHm.34	HPNX test log		
Verify that the user_notification_text “Performing download test” is shown when a firmware_upgrade() is sent. DApHm.19, DApHm.21, DApHm.39	HPNX test log		
Verify that the UDRD replied to each inband_tune_req() with an inband_tuning_granted() with the “tuning granted” status after receiving a firmware_upgrade() with the upgrade_source equal to the QAM inband channel. DApHm.18 DApHc.32, DApHc.33	HPNX test log		
Verify that the UDRD did not perform a reset after it has received a firmware_upgrade_complete() with the reset_request_status set to no_reset_requested, and that the UDRD removed the user_notification_text.	HPNX test log		
Verify that the UDRD can take control of the inband tuner after it has received a firmware_upgrade_complete() with the reset_request_status set to no_reset_requested. DApHm.28	HPNX test log		

Measurement	Acceptable Result	Results	Comments
Verify that the UDRD reset the download timeout timer every time a firmware_upgrade was sent. DpHm.37	HPNX test log		
Verify that the UDRD did not issue a PCMCIA reset until 10 seconds after the final firmware_upgrade() was sent. DpHm.35, DpHm.36	HPNX test log		
Verify that the UDRD did not issue a PCMCIA reset when the it received a firmware_upgrade() with the download_timeout_period of 0 and a timeout type set to "Both timeouts." DpHm.38	HPNX test log		
Verify that the UDRD performs a PCMCIA reset when it received a firmware_upgrade_complete() with the reset_request_status set to "PCMCIA reset." DpHm.28	HPNX test log		
Verify that the UDRD performs a POD reset when it received a firmware_upgrade_complete() with the reset_request_status set to "POD reset."	HPNX test log		

PICS Coverage for this Procedure

PICS Item	Quality
DpHm.1	Direct
DpHm.2	Direct
DpHm.2a	Direct
DpHm.4	Direct
DpHm.5	Direct
DpHm.10	Direct
DpHm.11	Direct
DpHm.18	Direct
DpHm.19	Direct
DpHm.21	Direct
DpHm.23	Direct
DpHm.28	Direct
DpHm.33	Direct
DpHm.34	Direct
DpHm.35	Direct
DpHm.36	Direct
DpHm.37	Direct
DpHm.38	Direct
DpHm.39	Direct
DpHc.32	Direct
DpHc.33	Direct

PICS Item	Quality
DpHm.8	Direct
DpHm.9	Direct

2.2.13 OOB EAS Tests

Introduction: This test verifies the UDRD correctly behaves when different priorities of ANSI J-STD-042-2002 cable_emergency_alert() messages are sent via the OOB.

Equipment: Host under test (UDRD), HPNX Test tool and OOB files (Low_Priority.hex, Medium_priority.hex, and Maximum_priority.hex, Motorola Channel Map.xls (see step 19).



Low_priority.hex



Meduim_priority.hex



Maximum_priority.he

x

Note: The attached files need to be copied to the computer running the HPNX application,

Procedure:

Step	Procedure
1.	Bring up the HPNX software on the given PC, and verify that the PC and HPNX are on the same isolated network.
2.	Under the Device tab, click on the name of the HPNX that you are working with.
3.	Select the "Pod Behavior mode" and click "connect", then, right click on the Trace window to select (at least) SPDU, TPDU and Payload for full vision of all layers.
4.	On the HPNX GUI click the Test tab. Select POD – "Low level test/ setup" window. In this window in the upper right hand corner click the Right arrow button to start the initialization process between the UDRD and the HPNX.
5.	Press Play button on the POD- Low level test/setup.
6.	Expand the "Extended Channel" tab, depending on the UDRD you may have to change the resource version of the HPNX to match that of the UDRD. Right click on the Session slot. Select "Change Resource Version". Enter the correct resource version needed to match the UDRD (version 1 or version 2 as defined in SCTE 28 section 8.9). Click OK. On the "Extended channel" tab press the Play button to open the extended channel resource.

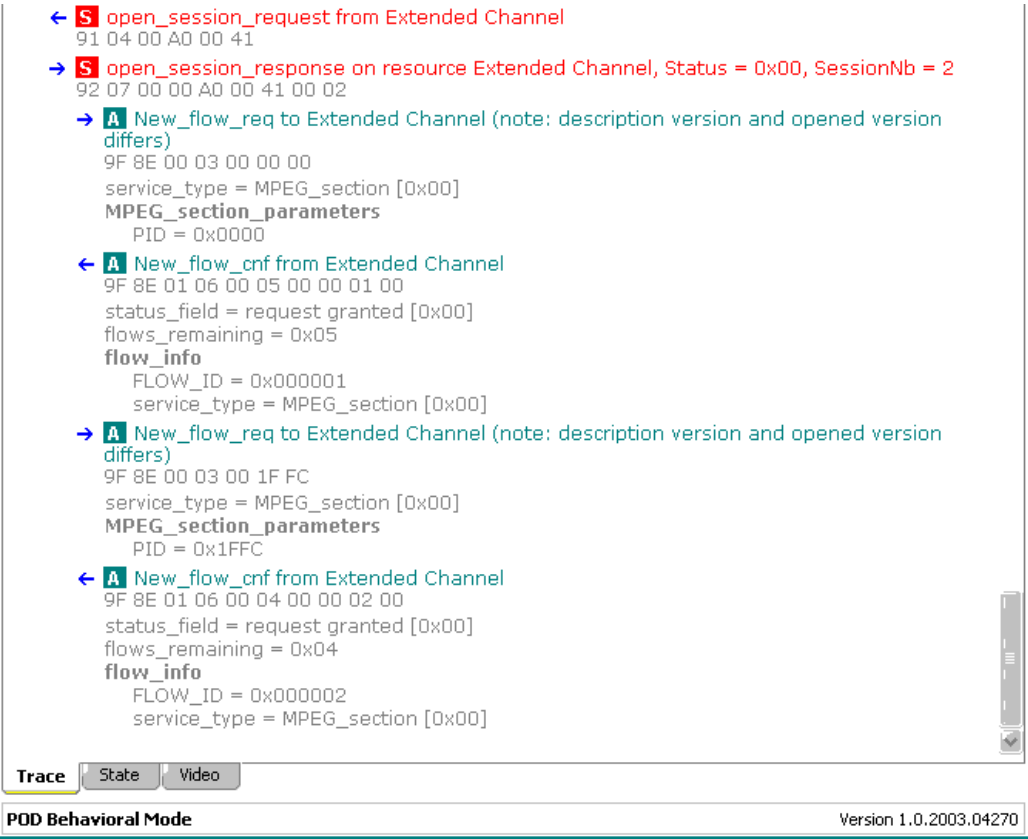
<p>7.</p>	<p>Verify that the UDRD issues a <code>New_flow_req</code> to Extended Channel requesting a <code>service_type = MPEG_section</code> with a <code>PID = 0x1FFC</code>. See example below.</p>  <p>Please note the <code>FLOW_ID</code> assigned by the UDRD in the <code>New_flow_cnf</code>.</p> <p>In this example the <code>FLOW_ID</code> assigned to the <code>PID 0x1FFC MPEG_section</code> flow is <code>0x000002</code>.</p>
<p>8.</p>	<p>Select "System Time" tab, and press the Play button.</p>
<p>9.</p>	<p>Under the "System Time" tab, expand the <code>system_time_inq</code> button.</p>
<p>10.</p>	<p>Ensure the <code>response_interval</code> is set to "0" and click Send.</p>

<p>11.</p>	<p>In the HPNX trace window note the Date received: Date and timestamp. See example below. Results in the Date and timestamp may vary depending on UDRD.</p>  <p>← S open_session_request from System Time 91 04 00 24 00 41</p> <p>→ S open_session_response on resource System Time, Status = 0x00, SessionNb = 3 92 07 00 00 24 00 41 00 03</p> <p>← A system_time_inq from System Time 9F 84 42 01 00 response_interval = 0</p> <p>→ A system_time to System Time 9F 84 43 05 00 00 0A 27 00 system_time = 0x00000A27 GPS_UTC_offset = 0x00</p> <p><i>Date received : Saturday, January 05, 1980 4:43:19 PM</i></p> <p>Trace State Video</p> <p>PDD Behavioral Mode Version 1.0.2003.04270</p>
<p>12.</p>	<p>Under the “Extended channel ” tab, expand the Flow Feed button.</p>
<p>13.</p>	<p>Next to the “SI table file” click the Browse button and select Mot_STT.hex from wherever you have stored it on the HPNX, and click “OPEN”.</p>
<p>14.</p>	<p>Enter the FLOW_ID that was noted in step 7 into the Flow ID window and click Send. NOTE: It is imperative that the correct Flow id be used in order for this test to function properly.</p>
<p>15.</p>	<p>In the “System Time ” tab, under the system_time_inq button, Ensure the response_interval is set to “0” and click Send.</p>
<p>16.</p>	<p>In the HPNX trace window verify the change in the Date received: Date and time stamp should be displayed similar to the example below.</p> <p>Note: The actual time (8:40:14) may differ as the UDRD clock will restart upon reception of the Mot_STT.hex file.</p>  <p>← A system_time_inq from System Time 9F 84 42 01 00 response_interval = 0</p> <p>→ A system_time to System Time 9F 84 43 05 2B 8A 53 6E 00 system_time = 0x2B8A536E GPS_UTC_offset = 0x00</p> <p><i>Date received : Friday, February 28, 2003 8:40:14 AM</i></p> <p>Trace State Video</p> <p>PDD Behavioral Mode Version 1.0.2003.04270</p>
<p>17.</p>	<p>In the “Extended channel ” tab, under the “Flow Feed” function. Next to the “SI table file” click the Browse button. Select the “Profile1.hex” file from wherever you have stored it on the HPNX, and click “OPEN”.</p>

18.	<p>Enter the FLOW_ID that was noted in step 7 into the Flow ID window and click Send. NOTE: It is imperative that the correct Flow id be used in order for this test to function properly.</p> <p>FYI: In this step immediately after you click send, the following tables will be sent to the UDRD.</p> <ol style="list-style-type: none"> 1. Network Information Table with a Carrier Definition table subtype. 2. Network Information Table with a Modulation Mode table subtype 1. 3. Network Information Table with a Modulation Mode table subtype 2. 4. Short Form Virtual Channel Table with a Defined Channel Map subtype. 5. Short Form Virtual Channel Table with a Virtual Channel Map subtype 1. 6. Short Form Virtual Channel Table with a Virtual Channel Map subtype 2. 7. Short Form Virtual Channel Table with a Virtual Channel Map subtype 3. 8. System Time Table. 9. Network Text Table with a Source Name Sub-table subtype.
19.	<p>On the UDRD using the channel up and down buttons or the remote control, verify that the channel map has been successfully loaded and that the UDRD can navigate the channel map. Attached is the channel map that is used for this test.</p> <div style="text-align: center;">  <p>"Motortola Channel Map.xls"</p> </div>
20.	<p>In the "Extended channel " tab, under the "Flow Feed" function. Next to the "SI table file" click the Browse button. Select the "Low_priority.hex" file from wherever you have stored it on the HPNX, and click "OPEN". Enter the FLOW_ID that was noted in step 7 into the Flow ID window and click Send.</p>
21.	<p>Verify that the UDRD ignores the Low_priority.hex message as the priority is set to "0".</p>
22.	<p>In the "Extended channel " tab, under the "Flow Feed" function. Next to the "SI table file" click the Browse button. Select the "Medium_priority.hex" file from wherever you have stored it on the HPNX, and click "OPEN". Enter the FLOW_ID that was noted in step 7 into the Flow ID window and click Send.</p>
23.	<p>Verify that the UDRD starts a scrolling message "EAS Blizzard Warning test message if you get this look outside and see if it is snowing".</p>
24.	<p>In the "Extended channel " tab, under the "Flow Feed" function. Next to the "SI table file" click the Browse button. Select the "Maximum_priority.hex" file from wherever you have stored it on the HPNX, and click "OPEN". Enter the FLOW_ID that was noted in step 7 into the Flow ID window and click Send.</p>
25.	<p>Verify that the UDRD force tunes to channel 163.</p>

Test Results: OOB EAS Test

Measurement	Acceptable Result	Results	Comments
Verify that the UDRD ignores the Low_priority.hex message as the priority is set to "0".	Host ignores EAS message.		
Verify that the UDRD starts a scrolling message "EAS Blizzard Warning test message if you get this look outside and see if it is snowing".	Host scrolls message.		

Measurement	Acceptable Result	Results	Comments
Verify that the UDRD force tunes to channel 163.	Host force tunes.		
Verify that the UDRD ignores the in-band EAS when an OOB is available.	Host ignores in-band EAS		

PICS Coverage for this Procedure

PICS Item	Quality
HNIEAS.2	Direct
HNIEAS.3	Direct
HNIEAS.10	Direct
HNIEAS.12	Direct
HNIEAS.13	Direct
HNIEAS.19	Direct
HNIEAS.21	Direct
HNIEAS.22	Direct
HNIEAS.23	Direct
HNIEAS.24	Direct
HNIEAS.25	Direct
FDCP.14	Direct

2.2.14 In-Band PSIP Test

The tests in this section verify the ability of the UDRD to navigate using in-band service information data.

The following Table describes digital services carried on three Transport Streams, modulated on RF channels 79, 80, and 81 on the Motorola feed at CableLabs. Each of the three multiplexes has been formed by play-out of a 30 second or one minute loop, therefore system time given in the STT will be discontinuous, and reflect an incorrect time of day (the loop starts at 12:05 pm, June 1, 2004 UTC).

Services in the multiplex on channel 79 are described by a TVCT. Services in channel 80 are described by a CVCT and include some two-part and some one-part channel numbers. Services on RF channel 81 are described by both TVCT and a CVCT, each of which assign different channel numbers to a given service. The Uni-Directional Receiving Device must disregard the TVCT if a CVCT is present in the Transport Stream.

The Table identifies the one- or two-part channel number that should be displayed to the user for each service on these three multiplexes. Two virtual channels are hidden, thus not visible until such time as they might be selected by reception of a Cable Emergency Alert Message. The table also identifies the short channel name and the extended channel name, which has been chosen to identify the content.

Note that channel 93-4 is interrupted once per loop (60 seconds) by an Emergency Alert event. EAS is tested in the following section.

Brief descriptions of each of the virtual channel, each is a 30-second or one-minute loop:

- | | |
|--------------|---|
| 85-1 | The Science channel, parental rating TV-14, Includes a Service Location Descriptor, a "GA94" MPEG-2 Registration Description, an AC-3 audio descriptor. |
| 85-3 | A golf match, containing one English and one Spanish audio track. Rating is TV-PG-L. |
| 85-90 | A data-only channel (one without a video or audio program element). |
| 86-1 | A Korean channel (KISB) containing a single audio track labeled (by ISO 639 Language Descriptor) as Spanish. The program is rated TV-G and includes an "SCTE" MPEG-2 Registration Descriptor. |
| 86-3 | A 30-second loop of the IFC channel. The program is rated TV-PG-DLSV, and includes two audio tracks. One is a Complete Main, and the other is a "Music & Effects" channel. The M&E track is labeled with a Component Name Descriptor entitled "Crowd Noise." |
| 87 | Game Show channel, rated MPAA-PG13. Includes two English-language audio tracks, each labeled with a Component Name Descriptor. The first track is named "Home announcers" and the second is "Away announcers." |
| 88 | BBC America, including three audio tracks (no ISO-639 Language Descriptors). The audio tracks are of type Complete Main, Visually Impaired (VI), and Hearing Impaired (HI), as identified in accompanying Audio Stream (AC-3) Descriptors. This service is rated for the Canadian region (region_code 0x02) for the "Canadian French" dimension as "16+." |

90 An HD channel (Hawaii volcanoes) with content advisory level TV-MA (for US region 0x01) and 16+ (Canadian region 0x02).

91-3 An audio-only channel of classical music.

92-2 Hidden channel (MTV Hits). The EAS message uses this as a Details channel.

92-3 Hidden channel (a Prince movie). The EAS uses this as a Details channel, but at such a low priority that the UDRD should not tune to it.

93-4 A channel (Ovation) that will be interrupted by the EAS event occurring once per loop.

Table. In-Band PSIP Tests

Virtual Channel (UI)	Short Name	Extended Channel Name	Rating	Descriptors*	Comments
85-1	Sci85-1	"Science Loop"	TV-14	CAD, AC3, GA94, SLD	TVCT 2-part channel number
85-3	Glf85-3	"Golf Loop"	TV-PG-L	CAD, AC3, 639pe, A1	TVCT 2-part channel number. Two audio tracks, English + Spanish
85-90	CL-Data	"Data-only Loop"	-	-	Data-only channel; no audio or video component.
86-1	KISB	"KISB-1 Korean"	TV-G	CAD, RC, 639pe, SCTE	The single audio track is labeled Spanish. (Note: the long channel name says Japanese, this has no reflection on the contents of the stream).
86-3	IFC-86	"IFC Loop on 86-3"	TV-PG-DLSV	CAD, AC3, CND	Two audio tracks: a CM track and an ME track. CND _{ME} ="Crowd noise"
87	Game-87	"Game Show Loop"	MCAA-PG13	CAD, 639pe, CND	Two English audio tracks, CND labels each. CND ₁ ="Home announcers" CND ₂ = "Away announcers"
88	BBC-88	"BBC America Loop"	16+ (Can. Fr.)	AC3 (x3), CAD (region 2), A2	Content advisory for Canadian region; Three audio tracks: CM, VI, HI; no ISO-639 lang. descriptors.
90	KCTS-HD	"KCTS HDTV Loop"	TV-MA, 16+	CAD (region 1, region 2)	Content advisories for both US and Canadian regions
91-3	Class91	"Classical Loop 91-3"	-	Audio-only channel	Audio-only
(92-2) (hidden)	MTVhits	"EAS Details channel"	-		Hidden channel. Accessed via EAS only.
(92-3) (hidden)	Prince	"Shouldn't be here"	-		Shouldn't be tuned by EAS (low priority)
93-4	Ovation	"Interrupted by EAS"	-		Will be interrupted by EAS event.

Legend

Service Types

DV	Digital video
DO	Data only
AO	Audio only

Audio Tracks

CM	Complete Main
ME	Music & Effects
HI	Hearing Impaired
VI	Visual Impaired

Descriptors

639pe	ISO-639 Language Descriptor at program-element level
639pg	ISO-639 Language Descriptor at program level
A2	Arbitrary Descriptors (not presently defined)
AC3	Audio Stream Descriptor
CAD	Content Advisory Descriptor (v-chip)
CND	Component Name Descriptor
ECND	Extended Channel Name Descriptor
GA94	MRD with "GA94" format identifier
MRD	MPEG-2 Registration Descriptor
RC	Redistribution Control Descriptor (Broadcast Flag)
SCTE	MRD with "SCTE" format identifier
SLD	Service Location Descriptor

Equipment: Host device under test, display monitor (if needed), 3 QAM modulators, 3 transport stream players, 3 transport stream files (“RF79n.mpg”, “RF80w2.mpg”, “RF81v2.mpg”)

Setup: Connect the UDRD to the combined RF output of the three QAM modulators (each fed by a stream player, set to RF channels 79, 80 and 81).

Procedure:

Step	Procedure
1.	With no POD module inserted in the UDRD, perform the initialization “channel scan” user setup step.
2.	Verify that channels 85-1, 85-3,86-1, 86-3, 87, 88, 90, and 93-4 are accessible (proper audio and video output/display, with audio synchronized to video) and labeled appropriately with the one- or two-part channel number given in the Table above. Notes: <ul style="list-style-type: none"> o channel 91-3 (an audio-only channel) may also be accessible. o Other unscrambled channels below channel 85 and above channel 100 may be accessible as well.
3.	Verify that channels 92-2 and 92-3 are not accessible by direct tuning or by channel surfing (channel-up, channel-down) as they are “hidden” channels.
4.	Verify that channels 84-2, 84-4, 84-6 are NOT accessible or displayed on any UI (these are delivered in a TVCT within a multiplex also containing a CVCT).
5.	Verify that the only channels accessible by channel surfing are those corresponding to in-the-clear services.
6.	Insert and initialize a POD module, and deliver an out-of-band channel map.
7.	Attempt to direct tune to channel 93-4 and verify it is not accessible (“no channel”)
8.	Attempt to channel surf to channel 93-4 and verify it is skipped

Test Results: In-Band PSIP Test

Measurement	Acceptable Result	Results	Comments
Tune to 85-1	“Science Loop” channel viewable, with audio synchronized to video		
Tune to 85-3	“Golf Loop” channel viewable, with audio synchronized to video		
Tune to 86-1	“KISB-1 Korean” channel viewable, with audio synchronized to video		
Tune to 86-3	“IFC Loop on 86-3” channel viewable, with audio synchronized to video		
Tune to 87	“Game Show Loop” channel viewable, with audio synchronized to video		
Tune to 88	“BBC America Loop” channel viewable, with audio synchronized to video		
Tune to 90	“KCTS HDTV Loop” channel viewable, with audio synchronized to video		
Tune to 93-4	“Interrupted by EAS” channel viewable , with audio synchronized to video (may be interrupted by EAS)		
Tune to 92-2	Channel not accessible (“no channel” or equivalent)		
Tune to 92-3	Channel not accessible (“no channel” or equivalent)		

Measurement	Acceptable Result	Results	Comments
Tune to 84-2	Channel not accessible ("no channel" or equivalent)		
Tune to 84-4	Channel not accessible ("no channel" or equivalent)		
Tune to 84-6	Channel not accessible ("no channel" or equivalent)		
Surf through all channels (channel-up)	Only in-the-clear services are accessible.		
Attempt to direct tune to channel 93-4	Verify it is not accessible ("no channel")		
Attempt to channel surf to channel 93-4	Verify it is skipped		

PICS Coverage for this Procedure

PICS Item	Quality
Hnop.1	Direct
Hnop.3B	Direct
Hnop.3C	Direct
Hnop.17	Direct
Hnop.10	Indirect
HNETdig_aud.1	Direct
HNETdig_aud.2	Direct
HstIBCS.1	Direct
HstIBCS.2	Indirect
HstIBCS.3	Direct
HstIBCS.4	Direct
HstIBCS.18	Indirect
HstIBCS.19	Direct
HstIBCS.69	Direct
HstIBCS.71	Direct
HstIBCS.72	Indirect
HstIBCS.93	Indirect
HstIBCS.125	Indirect
HstIBCS.132	Indirect
HstIBCS.143	Indirect
HstIBCS.145	Indirect
HstIBCS.183	Indirect
HSTDCC.67	Direct

2.2.15 In-Band EAS Tests

The tests in this section verify the ability of the UDRD to handle in-band EAS (Cable Emergency Alert) messages.

The Transport Stream modulated on channel 81 is used for these tests. Channel 81 includes three visible (90, 91-3 and 93-4) and two hidden (92-2 and 92-3) virtual channels. Channels 90 and 91-3 are included in the “exception list” and hence are not interrupted by the EAS event. Channel 93-4 will be affected by an EAS event.

NOTE: The transport streams (and modulator setup) is the same as for the previous test, 2.2.14 “In-Band PSIP”.

The EAS tests start (at the beginning of the loop) with a low-priority test, with no channel exceptions, that should be ignored by the UDRD because of its low priority.

Next, several two-second events are sent, each extending the time duration of the prior event. Then an infinite duration event is sent including text for display, followed 10 seconds later by a two-second event. At the end of those two seconds, return should be made to the channel that was initially interrupted.

Equipment: Host device under test, display monitor (if needed), QAM modulators, RF combiner, MPEG Stream Player.

Setup: In order to run this test you will need to have a MPEG stream player, 1 QAM modulators set up at EIA 81. The output of these modulators needs to be connected to the RF combiner. The output power on the combiner needs to be set at 0 dBmv. Connect the output of the Combiner with the power level set to 0 dBmv to the UDRD.

Procedure:

Step	Procedure
1.	With no POD module inserted in the UDRD, perform the initialization “channel scan” user setup step, if not already done in the “In-band PSIP tests”.
2.	Tune to channel 90 and verify that the full one-minute loop is viewable without interruption.
3.	Tune to channel 93-4. Verify that at 20 seconds following the start of the loop, an EAS event causes channel 92-2 to be accessed (MTV hits channel).
4.	Verify that the UDRD stays on channel 92-2 for 20 seconds (with no audio/video glitches in that period) and then returns to channel 93-4.

Test Results:

Measurement	Acceptable Result	Results	Comments
Tune to 90	Full one-minute loop viewable without interruption		
Tune to 93-4	20 seconds after start of loop, UDRD responds to EAS event, tunes to channel 92-2 and displays audio and video		

Measurement	Acceptable Result	Results	Comments
Uninterrupted access to Details channel	Audio and video are uninterrupted for 20 seconds following tuning to 92-2.		
Return to interrupted channel	20 seconds after tuning to 92-2, UDRD returns to channel 93-4		

PICS Coverage for this Procedure

Note: All tests must pass for these PICS to be satisfied.

PICS Item	Quality
HNIEAS.4	Direct
HNIEAS.5	Direct
HNIEAS.6	Direct
HNIEAS.7	Direct
HNIEAS.8	Direct
HNIEAS.9	Direct
HNIEAS.10	Direct
HNIEAS.11	Vendor Submitted Documentation
HNIEAS.14	Direct
HNIEAS.15	Direct
HNIEAS.16	Direct
HNIEAS.17	Indirect
HNIEAS.18	Direct
HNIEAS.19a	Indirect
HNIEAS.20	Direct
HNIEAS.22	Direct
HNIEAS.23	Direct
HNIEAS.24	Direct
HNIEAS.25	Direct
HNIEAS.26	Direct
HNIEAS.27	Direct
HNIEAS.28	Direct
HNIEAS.29	Direct
HNIEAS.30	Vendor Submitted Documentation
HNIEAS.31	Direct
HNIEAS.32	Direct
HNIEAS.33	Direct
HNIEAS.34	Direct
HNIEAS.35	Direct
HNIEAS.36	Direct
HNIEAS.37	Direct
HNIEAS.38	
HNIEAS.39	Direct

2.2.16 FAT Channel Maximum Individual Carrier Test

Introduction: This test verifies that the UDRD can receive FAT channels properly in the presence of undesired individual signals at a maximum level over frequency range from 5 to 42 MHz.

Equipment:: UDRD, spectrum analyzer, server, 64QAM mod, upconverter to low/mid/high channels and 2-way splitter.

Setup: Setup the system as described below.

Phy. Config: Power up UDRD. Connect the headend input stream to one of the output ports on the 2-way splitter. Connect the other output of the splitter to the signal generator. Connect the input port of the splitter to the spectrum analyzer. Set the undesired signal level on the generator and verify it on the analyzer. Once this is done disconnect the cable from the spectrum analyzer and connect it to the UDRD.

NOTE: Testing to be performed on low, mid and high channels

Procedure: Tune to a 64QAM channel at 0 dBmV. Set undesired signal to 5 MHz and increment in steps indicated in measurement column of table below up to 42MHz. Verify no service interruption (freeze frame, macro-blocking or absence of picture). Repeat test for the other 64QAM channels.

Test Results: FAT Channel Maximum Individual Carrier Test

Measurement	Acceptable Result	Results	Comments
Input set at +42 dBmV across 75 ohms; Frequency: 5 MHz HMIca.1	Proper reception		_____
10 MHz, input set at +42 dBmV	Proper reception		_____
19 MHz, input set at +42 dBmV	Proper reception		_____
34 MHz, input set at +24 dBmV	Proper reception		_____
42 MHz, input set at 0 dBmV	Proper reception		_____
54 MHz, input set at -10 dBmV	Proper reception		_____

PICS Coverage for this Procedure

PICS Item	Quality
HMIca.1	Direct

2.2.17 FAT Channel Adjacent Channel Characteristics Test

Introduction: This test verifies the performance of a particular modulation type (e.g. NTSC analog) in the presence of a higher power adjacent channel of a different modulation type.

Equipment: UDRD, Spectrum analyzer, one NTSC modulator, two QAM modulators, color bar generator capable of generating SMPTE 100% color bars.

Setup: NTSC Analog channel 78: Visual/Aural carrier ratio +13dB

NOTE: It is recommended that power levels be verified and adjusted using unmodulated carriers.

Procedure:

1. Desired Channel Modulation: NTSC Analog

Step	Procedure
1	Tune the receiving device to the NTSC channel under test
2	Verify that the power level of the NTSC analog channel is adjusted for +5 dBmV.
3	Verify that the lower adjacent 64QAM channel is set for a total power that is +1dB above the power of the NTSC analog channel
4	Verify proper reception of the desired channel, Remove 64QAM signal.
5	Adjust the 256QAM upper adjacent channel for a total power that is +6 dB above the power of the NTSC analog channel
6	Verify proper reception

NTSC Adjacent Channel Setup

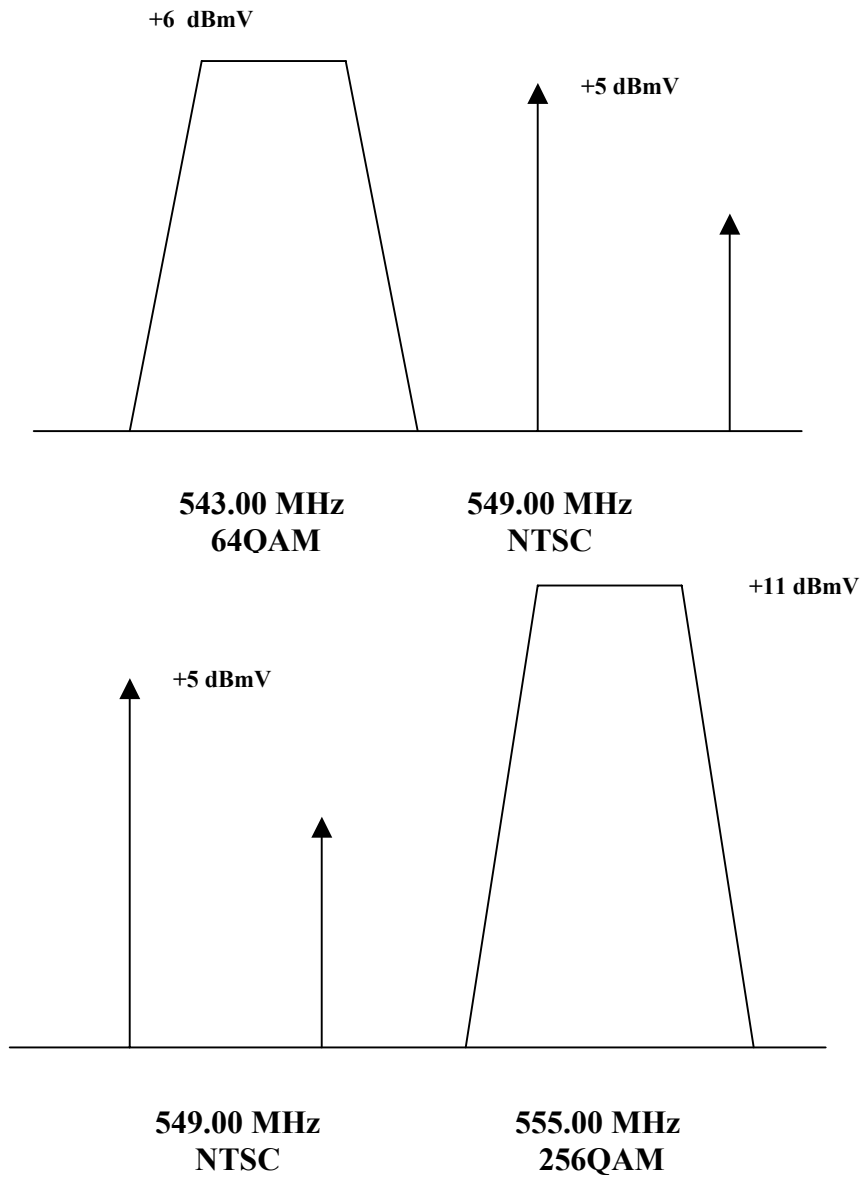

2. Desired Channel Modulation: 64QAM (Informative and Optional based on 256 QAM tests successful completion)

Step	Procedure
1	Tune the receiving device to the 64QAM channel under test
2	Verify that the 64QAM channel is set for a total power that is -6 dBmV.
3	Verify that the lower adjacent NTSC analog channel is set for a total power that is +21 dB above (+15 dBmV) the power of the 64QAM channel.
4	Verify proper reception
5	Remove NTSC analog channel
6	Adjust the 256QAM upper adjacent channel for a total power that is +21 dB above (+15 dBmV) the power of the 64QAM
7	Verify proper reception

64QAM Adjacent Channel Setup

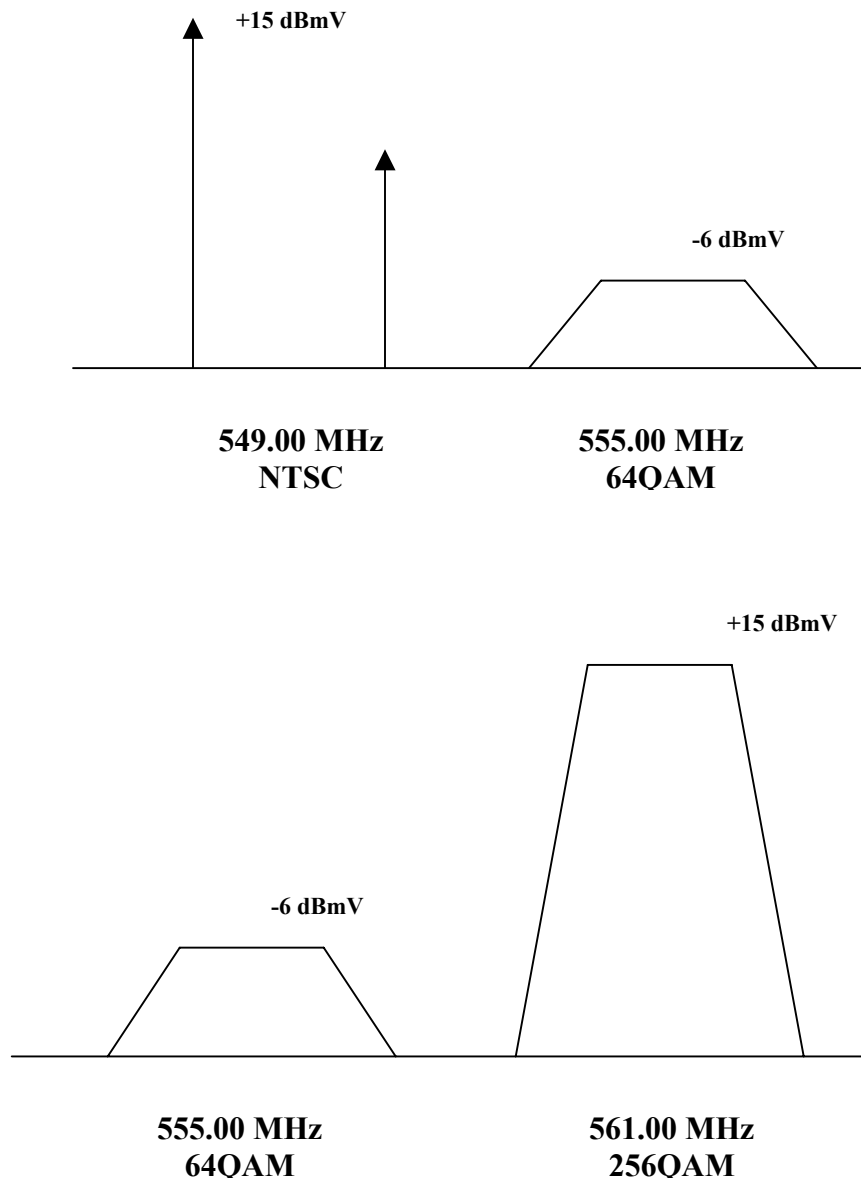

3. Desired Channel Modulation: 256QAM

Step	Procedure
1	Tune the receiving device to the 256QAM channel under test.
2	Verify that the power level of the 256QAM channel is adjusted for -1 dBmV
3	Verify that the lower adjacent NTSC analog channel is set for a total power that is $+16$ dB above ($+15$ dBmV) the power of the 256QAM channel
4	Verify proper reception
5	Remove NTSC analog channel
6	Adjust the 64QAM upper adjacent channel for a total power that is $+11$ dB above ($+10$ dBmV) the power of the 256QAM channel
7	Verify proper reception of the desired channel.

256QAM Adjacent Channel Setup

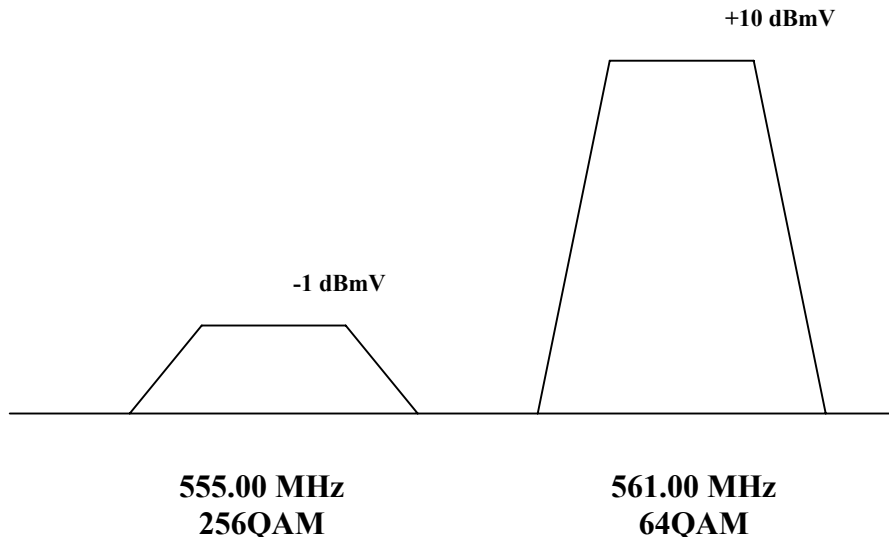
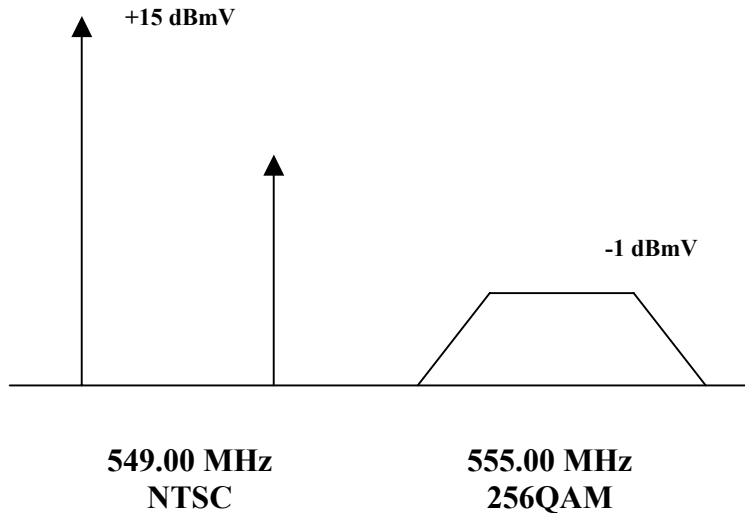

Test Results: FAT Channel Adjacent Channel Characteristics Test

Measurement	Acceptable Result	Results	Comments
NTSC Analog channel relative to 64QAM at +1dB and 256QAM at +6 dB HRFAcc.1 HRFAcc.3	Receiving device properly tunes and displays desired channel at a CCIR level of 3 or better		_____
64QAM channel relative to NTSC Analog at +21 dB and 256QAM at +21 dB HRFAcc.4 (Informative and Optional based on 256 QAM tests successful completion)	Receiving device properly tunes and displays desired channel		_____
256QAM channel relative to NTSC Analog at +16 dB and 64QAM at +11 dB HRFAcc5, HstDr.1	Receiving device properly tunes and displays desired channel		_____

PICS Coverage for this Procedure:

PICS Item	Quality
HRFAcc.1	Indirect
HRFAcc.3	Direct
HRFAcc.4	Indirect
HRFAcc.5	Direct
HstDr.1	Direct

2.2.18 FAT Channel High signal Test

Introduction: This test verifies that the UDRD will tune and display video in the presence of a non-tuned signal with an amplitude of +20dBmV

Equipment: UDRD, 64QAM video signal at 0 dBmV on mid channel, NTSC at +20 dBmV on high channel

Setup: UDRD connected to mid channel QAM

Procedure:

Step	Procedure
1	Tune the receiving device to the QAM channel.
2	Verify proper reception

Test Results: FAT Channel High Signal Test

Measurement	Acceptable Result	Results	Comments
Reception under strong alternate channel	Proper reception		

PICS Coverage for this Procedure

PICS Item	Quality
HMIca.2	Direct

2.2.19 FAT Channel Functional Test

Introduction: This test verifies that the UDRD is meeting lowest and highest frequencies requirements and weakest and strongest RF signal levels.

Equipment: UDRD, Reference POD, Spectrum Analyzer, NTSC source, modulator, upconverter, server, 64QAM modulator, 256QAM modulator, POD not required , 15 dB pad.

Setup: Setup the system as described below.

Phy. Config: Powered up UDRD (with or without POD) connected to a TV. Connect the Spectrum Analyzer to the RF tap in the same RF network that feeds the UDRD.

NOTE: All tests to be performed on low, mid and high channels

Procedure:

NTSC

1. Set NTSC modulator to channel to be tested.
2. With a 15dB pad on the output of the NTSC modulator, adjust the output level until it read 0 dBmV on the spectrum analyzer. Then remove the 15 dB pad. This will test the +15 dBmV RF signal level. Make sure that channel is displayed properly on the TV.
3. On the NTSC modulator adjust the output level of the modulator until it read 0 dBmV on the spectrum analyzer. Make sure that channel is displayed properly on the TV.
4. With a 15dB RF pad on the output of the modulator, adjust the output level of the modulator until 0 dBmV is measured on the screen of the Spectrum analyzer.
5. Remove the 15 dB pad from the output of the modulator. Monitor the screen of the analyzer, the carrier level should now read +15dBmV.
6. The analog aural carrier (audio) sits at 4.5MHz above the video carrier. Adjust the frequency on the spectrum analyzer accordingly to view the audio carrier level. Then adjust the output audio level in the modulator to vary between -10dBc and -17dBc and listen to the audio on the TV to confirm that the UDRD is able to lock and output the audio correctly.

64QAM

7. Set 64QAM modulator to channel to be tested.
8. With a 15dB pad on the output of the 64QAM modulator, adjust the output level until it read 0 dBmV on the spectrum analyzer. Then remove the 15 dB pad. This will test the +15 dBmV RF signal level. Make sure that channel is displayed properly on the TV.

9. On the modulator adjust the output level of the 64QAM modulator until it read 0 dBmV on the spectrum analyzer. Replace the 15 dB pad. This will test the -15 dBmV RF signal level. Make sure that channel is displayed properly on the TV.

256QAM

10. Set 256QAM modulator to channel to be tested.
11. With a 15dB pad on the output of the 256QAM modulator, adjust the output level until it read 0 dBmV on the spectrum analyzer. Then remove the 15 dB pad. This will test the +15 dBmV RF signal level. Make sure that channel is displayed properly on the TV.
12. On the modulator adjust the output level of the 256QAM modulator until it read +3 dBmV on the spectrum analyzer. Replace the 15 dB pad. This will test the -12 dBmV RF signal level. Make sure that channel is displayed properly on the TV.

Test Results: FAT Channel Functional Test

Measurement	Acceptable Result	Results	Comments
RF Tuning range from 54MHz-864MHz HFATrf.8, HFATrf.9	Proper reception		_____
64QAM @ +/- 15 dBmV HFATrf.10	Proper reception		_____
256QAM @ -12 dBmV to +15 dBmV HFATrf.11, HFATrf.1, HFATrf.2	Proper reception		_____

PICS Coverage for this Procedure

PICS Item	Quality
HFATrf.1	Direct
HFATrf.2	Direct
HFATrf.8	Direct
HFATrf.9	Direct
HFATrf.10	Direct
HFATrf.11	Direct

2.2.20 FAT Channel HRC/IRC Tuning Test

Introduction: This test verifies HRC/IRC tuning of UDRD.

Equipment: NTSC source, modulator, analog HRC upconverter, channel 5, analog IRC upconverter channel 5.

Setup: Prepare the receiving device in the proper tuning mode. To set C6U to HRC/IRC mode, Select Converter A or B, push down arrow until "option menu" appears. Push "right" arrow once, then down arrow twice until "mode" appears. Push right arrow on front panel display until desired modulation (HRC/IRC) is displayed. Push the "enter" button to lock desired settings. Set visual carrier to 0 dBmV and Analog aural carrier signal to -10dBc at the RF input to the UDRD.

Procedure:

1. Connect HRC analog channel 5 (78.0039 MHz)
2. Cause UDRD to tune to HRC analog channel 5
3. Repeat set-up procedure above change input to unscrambled HRC digital source.
4. Cause UDRD to tune to unscrambled digital channel configured as HRC.

Note: This is the only channel on the plant in testing of HRC using unscrambled digital channel.

5. Verify proper reception.
6. Connect IRC analog channel 5 (79.2625 MHz)
7. Cause UDRD to tune to IRC analog channel 5.
8. Repeat set-up procedure above change input to unscrambled IRC digital source.
9. Cause UDRD to tune to unscrambled digital channel configured as IRC.

Note: This is the only channel on the plant in testing of IRC using unscrambled digital channel.

10. Verify proper reception.

Test Results: FAT Channel HRC/IRC Tuning Test

Measurement	Acceptable Result	Results	Comments
HRC analog channel 5	Proper reception		
HRC Digital Channel	Proper Reception		
IRC analog channel 5	Proper reception		
IRC Digital Channel	Proper Reception		

PICS Coverage for this Procedure

PICS Item	Quality
HFATrf.5	Direct
HFATrf.13	Indirect
Hnop.2	Direct
HVBIPT.1	Direct

2.2.21 FAT Channel Micro-reflection Test

Introduction: This test fulfills band pass ripple, group delay and static ghost impairments.

Equipment: HP11759D Ghost Simulator, (or TAS or Rhode and Schwarz SFQ.) 256QAM source, Spectrum analyzer, Analog NTSC source.

Setup: Set up the ghost simulator as described below

Procedure:

1. Connect analog NTSC source on mid channel at 0 dBmV.
2. Set the ghost generator primary path for Phase, 0dB attenuation, 0 phase, 0 delay, LO oscillator to 207 MHz at +10 dBm.
3. Set the ghost generator secondary path to the conditions shown in line 1 of the measurement column of the table below.
4. Verify proper video reception.
5. Replace NTSC source with 256QAM signal on mid channel at 0 dBmV.
6. Set the ghost generator secondary path to the conditions shown in the next line of the measurement column of the table below.
7. Verify proper video reception.
8. Repeat steps 6 and 7 for each subsequent line of the measurement column of the table below.

Note: 256 QAM modulations will represent the worst-case scenario for this test. A micro-reflection of -13 dB @ 0.5 uSec is required in order to meet the 250 uSec group delay specification.

Test Results: FAT Channel Micro-reflection Test

Measurement	Acceptable Result	Results	Comments
Phase, -13 dB @ 0.5 uSec, 0 degrees referenced to RF channel center freq. (NTSC) HFATrf.32	Proper reception		_____

Measurement	Acceptable Result	Results	Comments
Phase, -13 dB @ 0.5 uSec, 0 degrees referenced to RF channel center freq. (256QAM) HFATrf.26, HFATrf.28, HFATrf.29	Proper reception (The test must pass all four 256QAM secondary path conditions shown in this table, to pass this PICS item.)		_____
Phase, -15dB @ 1 uSec, 0 degrees referenced to RF channel center freq. (256QAM) HFATrf.29	Proper reception		_____
Phase, -20 dB @ 1.5 uSec, 0 degrees referenced to RF channel center freq. (256QAM) HFATrf.29	Proper reception		
Phase, -30 dB @ 4.5 uSec, 0 degrees referenced to RF channel center freq. (256QAM) HFATrf.29	Proper reception		

PICS Coverage for this Procedure

PICS Item	Quality
HFATrf.26	Direct
HFATrf.28	Direct
HFATrf.29	Direct
HFATrf.32	Direct

2.2.22 FAT Channel Phase Noise Tolerance

Introduction: This test verifies operation of QAM signals under phase noise conditions

Equipment: HP model #8675A FM signal generator, (NoiseCom model #7102) Audio white noise source, passive double balanced mixer (Mini circuits ZFM 15 or equivalent), and 256QAM source at 150 MHz, spectrum analyzer

Setup: FM signal generator to 63MHz at +10dBm. Connect the audio noise source to FM input on the signal generator. Connect signal generator to spectrum analyzer. Spectrum analyzer freq. to 63 MHz, 50kHz span, resolution BW to 1 kHz. Adjust FM deviation of the signal generator so that spectrum analyzers 10 kHz offset measures -56dBc . Video averaging "on" is suggested to obtain a stable reading on spectrum analyzer.

(Alternate: QAM source at IF, generator at 257 MHz)

This set up initializes phase noise at -86dBc per Hz at 10 kHz offset. 30dB correction factor corresponds to 1 kHz resolution bandwidth.

Connect signal generator output to mixer L port. Connect 256 QAM signal to mixer I port at +6 dBmV. Connect mixer output to UDRD input, verify that the signal level at the UDRD is 0dBmV.

Procedure:

1. Tune UDRD to channel 13.
2. Verify proper reception

Test Results: FAT Channel Phase Noise Tolerance

Measurement	Acceptable Result	Results	Comments
Phase noise tolerance -86dBc @ 10 kHz	Proper reception		

PICS Coverage for this Procedure

PICS Item	Quality
HFATrf.27	Direct

2.2.23 FAT Channel AM Hum Modulation Immunity

Introduction: This test verifies operation of UDRD in the presence of hum

Equipment: HP11759D Ghost Simulator, (TAS or Rhode and Schwarz SFQ.) 256QAM source, Spectrum analyzer.

Setup: 256QAM signal on the mid channel at 0 dBmV. Set the ghost generator primary path for 0dB attenuation, 0 phase, 0 delay.

Procedure:

1. 256QAM signal on the mid channel at 0 dBmV.
2. Set LO oscillator to 207 MHz and set to +10 dBm.
3. Set the ghost generator primary path for 0dB attenuation, 0 phase, 0 delay
4. Set ghost generator secondary path for Doppler, 0 delay, -37 dB attenuation, 120Hz Doppler
5. Verify proper reception.

Test Results: FAT Channel AM Hum Modulation Immunity

Measurement	Acceptable Result	Results	Comments
3% hum modulation at 120Hz	Proper reception		

PICS Coverage for this Procedure

PICS Item	Quality
HFATrf.23	Direct

2.2.24 Combined Distortions Test

This test verifies the successful decompression and display of an MPEG-2 compressed video bit stream after demodulation, using 256QAM transmission in the presence of multiple combined channel impairments. The impairments consist of a -18dB ghost at $0.5\mu\text{S}$, 36dB C/N and 16 uS bursts of noise at -12dBmV

Equipment: UDRD, 256QAM video source set to channel 82 (573MHz), Echo Generator (HP11759D Ghost Simulator, or equivalent), 2 Noise generators, one with gating option (NoiseCom model 7109 or equivalent), Pulse generator (HP8116A or equivalent), 2-2 way splitters, Oscilloscope, (HP89441a or equivalent) vector signal analyzer.

Set up: Set test up as shown in diagram below. QAM256 RF input to the UDRD should be -7dBmV (-55.7dBm) with 36dB C/N ratio and 16 uS noise bursts of -12 dBmV (-60.75 dBm).

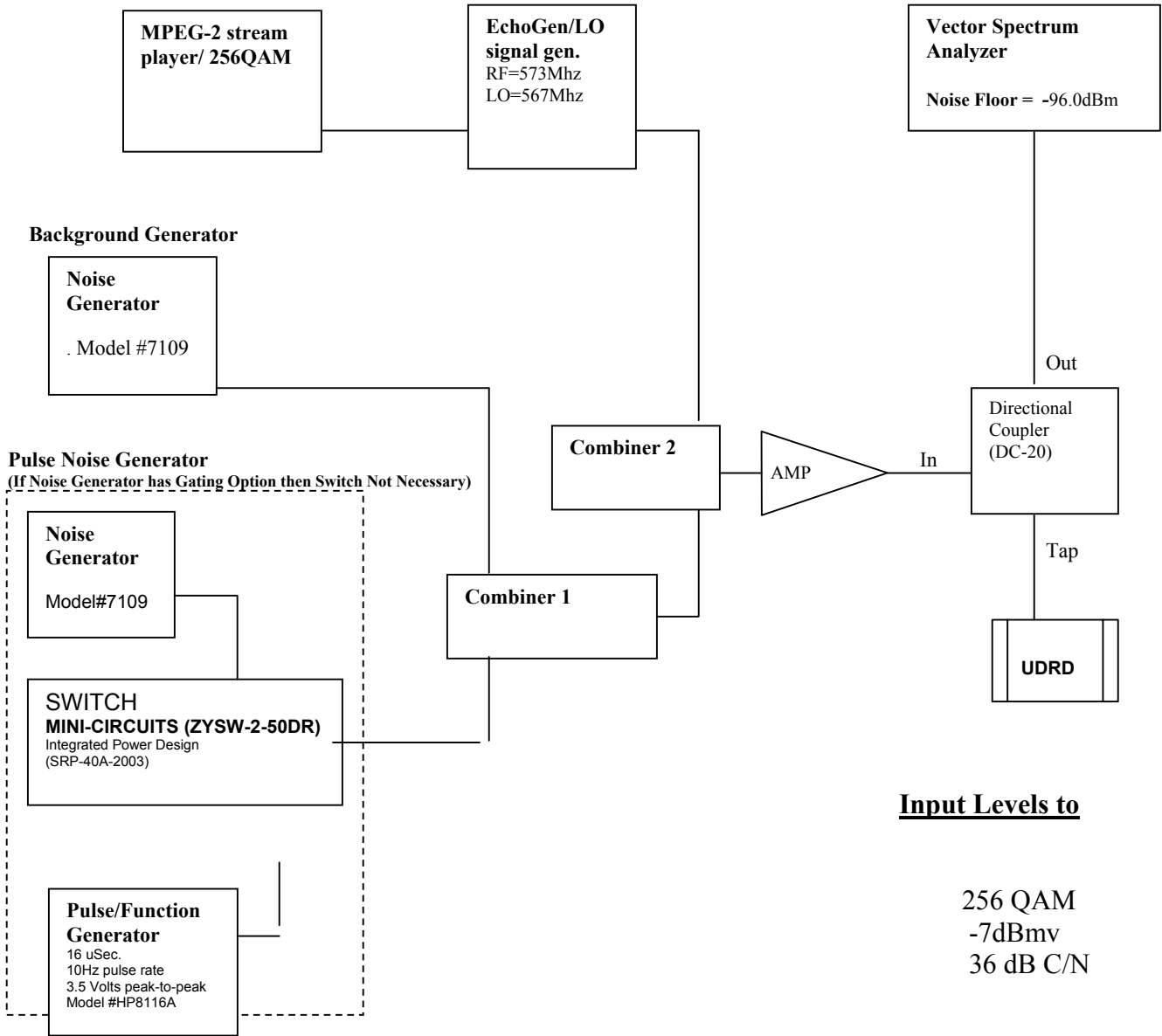

Input Levels to

256 QAM
-7dBmv
36 dB C/N

Equipment list:

Manufacturer	Model Number	Quantity	Description
Sencore	AD951	1	MPEG Analyzer/Player
Radyne ComStream	QAM256	1	QAM modulator
NoiseCom	UFX 7109	2	Noise Generator
HP	11759D	1	Ghost Simulator
	8657B	1	Signal Generator
	Vectra XP/60	1	PC for Ghost simulator
	8116A	1	Pulse Generator
	89441A	1	Vector Spectrum Analyzer w/RF section
	8447D	1	Low Noise Amplifier
Mini-Circuits	ZYSW-2-50DR	1	Switch
Integrated Power Designs	SRP-40A	1	PS for switch
EMCT	4112P	1	50 Ohm, 1 watt, SMA male terminator
Regal	GRS2DGV	2	Splitter/Combiner
	RDCT10-20	1	Directional Coupler
Trilithic	BMA-781	1	Variable Attenuator

Switch: Per Host Combined Distortion Test

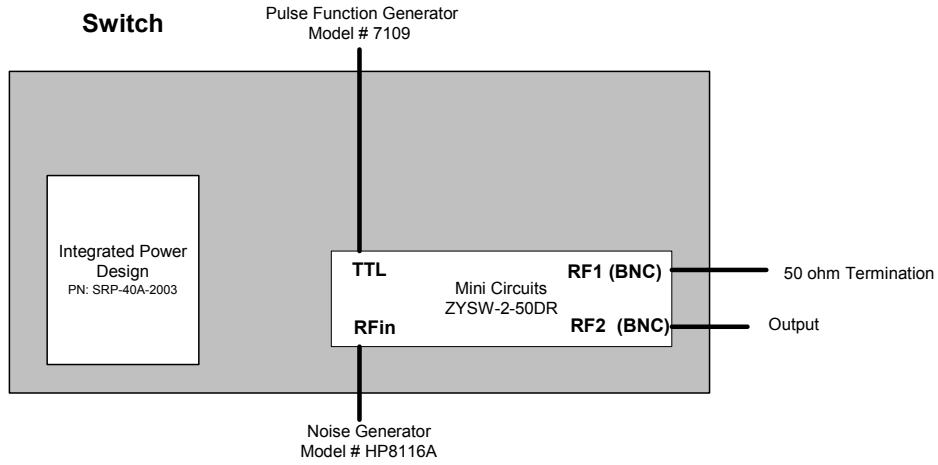

BOM

Mini-Circuits	ZYSW-2-50DR	1	Switch (Ref. Dg03-218) below
Integrated Power Designs	SRP-40A-2003	1	P/S for switch (Ref. SRP-40A) below
Generic Circuit Box		1	

Component Specs.



dg03-218[1].pdf
(76 KB)



SRP-40A[1].pdf
(133 KB)



4112p.pdf (58 KB)

Step	Equipment set-Up Procedure:
1.	(Pulse) noise generator set up
2.	Power on the 7109 noise generator and press “noise attenuation” button and enter “347” and press enter, in order to set the pulse noise generator attenuation to 34.7 dB.
3.	<p>Power on the HP 8116a (pulse function generator) and configure it as follows:</p> <p>Set Mode to “Norm” Set single pulse high level (HIL) to “3.50” this set the pulse amplitude to 3.5v p-p* Set single pulse level (LOL) to “0” Set “frq” to “10.0 Hz” repetition rate Set “Wid” to “16 uSec” pulse width Verify the “disable” LED is off and press the “disable” button if necessary. Verify the “CMPL” LED is off and press the “CMPL” button if necessary. Verify the proper pulse on the Oscilloscope (Tek 2465) 1V/Div, 15 uS/Div</p> <p>*Note: Exceeding 3.5V will damage the Switch.</p>
4.	Connect the “Output” of the HP 8116a (pulse function generator) to the switch.
5.	Connect the noise generator output to the switch.
6.	Connect the switch RF output to oscilloscope at 5mV/Div, 3uSec/Div to verify the gated noise.
7.	Take the output of the switch and connect it to combiner 1.
8.	Connect all remaining equipment per the block diagram above.

9.	MPEG-2 Video Stream Player and QAM Modulator Set-up
10.	Connect MPEG-2 Stream Player playing a High Definition “moving zone plate” stream to a 256 QAM modulator, see your MPEG-2 player documentation to see how to play out MPEG-2 transport stream.
11.	<p>For test conducted at CableLabs a Harmonic Network Services Gateway (NSG) QAM256 modulator will be used. To set up the Harmonic NSG QAM modulator follow the instructions below.</p> <ol style="list-style-type: none"> 1.) Set the frequency on the modulator to 573 MHz. 2.) Set the modulation type to 256 QAM. 3.) Select an interleaver depth of I=128, J=4. 4.) Set the modulator output level to approximately +51dBmV. 5.) Insert the appropriate amount of attenuation on the back of the modulator in order to achieve “+37dBmV”. If the overload light on the ghost generator is lit, add attenuation until the overload light does not flash. (Note: The HP 89441A echo generator accepts an input level of up to +37dBmV before overload. Lower levels decrease S/N.)
12.	Echo Generator Set up
13.	<p>Power up echo generator PC (PC defaults to Windows at power up, exit windows) and at DOS prompt type “cd chansim”, then “chansim” again. At the main menu type “G”. DO NOT PRESS THE “enter” key.</p> <p>Set the echo generator to the following parameters:</p> <p style="padding-left: 40px;">RF Freq to 573 (center freq of QAM mod) LO freq to 567 (6 MHz below RF freq). Set path 1 to “Phase”, 0 delay, 0 degrees, and 0 dB attenuation. Set path 2 to “Phase”, 0.5uSec delay, 0 degrees and 18 dB attenuation. Set paths 2 to 6 to “OFF” (temporarily removes ghosted signal).</p> <p>Note: After set up has been completed path 2 MUST be set to “Doppler” to enable the echo impairment. This will be executed later in this procedure.</p>
14.	LO Signal Generator Set-up
15.	<p>Set the HP 8657B signal generator to the following parameters: (Note: the signal generator is physically connected to, the echo generator HP11759D)</p> <p style="padding-left: 40px;">Set the frequency by pressing the “FREQ” button and enter “567MHz” Set the amplitude by pressing the “AMPTD” button and enter “10 dBm”</p>
16.	Echo Generator RF output verification/ HP 89441a Vector Analyzer set up procedure:
17.	<p>Turn off the background noise.</p> <p>On the 7109 noise generator and press “noise attenuation” button and enter “999” and press enter, in order to set the pulse noise generator attenuation to 99.9 dB.</p>
18.	<p>Turn off the pulsed noise.</p> <p>On the second 7109 noise generator and press “noise attenuation” button and enter “999” and press enter, in order to set the pulse noise generator attenuation to 99.9 dB.</p>

19.	To compensate the input for the 75 to 50 ohm adapter, select "Input" on the front panel, press the "ch1 input Z" to select 75 ohm.
20.	Select "Instrument Mode" on the front panel and press the "Vector" option on the VSA screen.
21.	Press the "RF (2-2650MHz normal)" option on the screen.
22.	Select "Frequency" on the front panel and select "center" on the display options, enter "573" on the front panel and press the "MHz" option on the screen.
23.	Select "Span" on the display enter "6" on the front panel and press the "MHz" option on the screen.
24.	Select "Marker Function" on the front panel, select "band power marker" option on the display.
25.	Select "band center" option on the display, enter "573" on the front panel and press the "MHz" option on the screen.
26.	Select "bandwidth" option on the display, and enter "6" on the front panel and press the "MHz" option on the screen.
27.	On the display Verify "band power marker" is on. (If not turn it on)
28.	On the front panel press the "ResBW/Window" button select the "num Freq Pts" option on the front panel enter "1601" and select enter on the display.
29.	On the front panel press the "Range" button using the "up arrow" and/or "down arrow" buttons until the channel 1 "over" and "half" range LED's are illuminated. If the "over" and "half" LED's are illuminated, range "up arrow" on the front panel and verify that the LED's extinguish.
30.	On the front panel press the "average" button and select the "num averages" option on the display, enter "32" and select enter on the display.
31.	On the display verify average is "on" (if not turn it "on") to obtain stable reading on vector analyzer.
32.	Observe "Power" reading in the lower left hand corner of the display, note that value here; _____ (this value will be approximately -31.7 dBm)
33.	To set the power level to -7dBmV at the input to the UDRD the following loss must be taken in to consideration, combiner 2 applies 3.5 dB of loss, additional attenuation must be added to the RF output of the echo generator so that the power level at the input of the UDRD is -7dBmV . Add the necessary attenuation in the form of a fixed attenuator to the output of the echo generator to obtain -35.75 dBm on the VSA.

34.	<p>The value of -35.75 dBm on the VSA reflects an input level of -7dBmV to the UDRD based on the formula below.</p> <p><u>Legend:</u> X = Power level read on Vector signal analyzer. 0dBmV = 48.75 dBm</p> <p>Formula: -35.75 dBm + 48.75 = +13 dBmV</p> <p>Accounting for the loss of the DC-20 the level present at the UDRD is -7 dBmV</p>
35.	<p>(Background) noise generator set up</p>
36.	<p>Remove the QAM signal by tuning off channel. On the QAM modulator front panel press the “frq” button, adjust the modulator using the up/down arrows until 519.000 are displayed on the LCD and press the “enter” button.</p>
37.	<p>On the noise generator and press “noise attenuation” button and enter “733” and press enter, in order to set the background noise generator attenuation to 73.3dB.</p>
38.	<p>On the front panel of the VSA press the “range” button, on the display find the “chl range”, on the front panel of the VSA, press the “down arrow” until “chl range” is set to -50 dB.</p>
39.	<p>On the vector analyzer verify the “Power” reading in the lower left hand corner of the display Verify that the Power level is -71.7dBm. If -71.7dBm is not achieved go back to step 37 and adjust the noise attenuation to achieve the desired level.</p> <p>Record the final attenuation setting here _____.</p> <p>Note: This is the power that is measured at the pass-thru leg of the DC-20. The actual value that will be sent to the UDRD will be 20 dB lower because of the DC-20 tap. The actual value will be -42.95 dBmV (-91.7 dBm). This is the desired background noise level in that will be used in this test (36 dB C/N)</p>

40.	(Pulse) noise generator signal set up
41.	Turn off the background noise. On the 7109 noise generator and press “noise attenuation” button and enter “999” and press enter, in order to set the pulse noise generator attenuation to 99.9 dB.
42.	On the front panel of the VSA press the “range” button, on the display find the “chl range”, on the front panel of the VSA press the “up arrow” until “chl range” is set to -30 dBm.
43.	On the noise generator and press “noise attenuation” button and enter “347” and press enter, in order to set the pulse noise generator attenuation to 34.7 dB.
44.	On the HP 8116a (pulse function generator) press the “COMPL” button to turn the LED “on”.
45.	On the vector analyzer verify that the “Power” reading in the lower left hand corner of the display is -40.75 dBm. If -40.75 dBm is not achieved go back to step 43 and adjust the noise attenuation to achieve the desired level. Record the final attenuation setting here _____. Note: This is the power that is measured at the pass-thru leg of the DC-20. The actual value that will be sent to the UDRD will be 20 dB lower because of the DC-20 tap after accounting for the loss of the switch the actual value that will be sent to the UDRD will be approximately -11.95dBmV.
46.	On the HP 8116a (pulse function generator) press the “COMPL” button to turn the LED “off”.
47.	Echo Generator second path reflection verification.
48.	Turn off the pulsed noise. Press the “disable” button on the front panel of the pulse generator to turn the LED “on”.
49.	Add the QAM signal by tuning back on channel. On the QAM modulator front panel press the “frq” button, adjust the modulator using the up/down arrows until 573.000 are displayed on the LCD and press the “enter” button.
50.	From the echo generator PC, set path 2 to “Phase”, 0.5uSec delay, 0 Degrees and 18db attenuation.

On the Vector signal analyzer verify that the ripple reflection impairment is present on the 256QAM @ 573Mhz.

Verification process on the vector signal analyzer:

- 1.) The ripple pattern on the screen should consist of three ripples within the 6Mhz channel.
- 2.) On the front panel press "RefLvl/Scale", on the display press the "Y ref level" enter "-50 dBm" and press the "dBm" option of the screen.
- 3.) Select the "Y per div" on the display enter "2" and select the "db" option on the display
- 4.) On the front panel press the "average" button on the display press the "num averages" option enter "100" and press "enter" on the display.
- 5.) On the front panel press the "Marker" button, using the wheel on the front panel adjust the marker position to the middle ripples highest position, this should be around -57dBm.
- 6.) Adjust the marker position to the right (or left) "valley" lowest position (may have to try both side to achieve the lowest reading); this should be approximately -59dBm.
- 7.) The peak-to-peak difference between highest and lowest level should be approximately 2dBm.

Below is an example of what this will look like on the vector signal analyzer:

51.



52.

Bring UDRD to stable operating condition. (Consult UDRD users manual)

53.	Final Connection set up
54.	Turn on the background noise. On the 7109-noise generator and press “noise attenuation” button and enter the final value recorded above in the background noise setup and press enter.
55.	Turn on the pulsed noise. Press the “disable” button on the front panel of the pulse generator to turn the LED “off”.
56.	Measurement Procedure:
57.	Connect the combined output to the UDRD and verify proper reception. Proper reception is no macro blocking, freeze framing, or complete loss of service.

Test Results: Host combined distortions test

Measurement	Acceptable Result	Results	Comments
With both the pulse noise and the background noise parameters the RF level going in to the UDRD will be – 7dBmV and C/N will be 36dB. Turn on path 2 of the Echo Generator by selecting “Doppler” and observe UDRD for 3- 20-second intervals. Repeat Intervals if macro block, freeze frame or loss of service occurs to verify failure.	Proper reception		

PICS Coverage for this Procedure

PICS Item	Quality
HRFAcc.8	Direct
HRFAcc.8a	Direct
HFATrf.31	Indirect

2.2.25 FDC Adjacent Channel Characteristics Test

Introduction: This test verifies the performance of FDC reception in the presence of higher power adjacent channels of various modulation types.

Equipment: UDRD, TTC Firebird 6000A communications analyzer, RF Networks 5450 QPSK Modem, HPNX emulator, POD extender with FDC serial out (clock on pin CBE1, data on pin AD14), NTSC ch 5 source at +15 dBmV, 256QAM ch. 5 source at +15 dBmV, Spectrum analyzer, RF combiner.

NOTE: CableLabs has an alternate equipment setup using a modulator (see optional procedure below) with an internal PRBS generator (Broadcom BCM93133).

Setup: Settings for Firebird: Data: 2¹⁵-1; Gen Clk: Synth; Timing Mode: Sync; Menu Intf Setup: Lab; Menu Synth Freq: 1.544; Signal Gen Freq 1544000; Signal Rcv freq 1544000 or Error Bit Errs; Analysis Mode: Continuous
Connect Firebird clock and data lines to QPSK modem at -7 dBmV, 74 MHz, 1.544 Mbps.
Connect modem to UDRD cable input.
Connect HPNX in POD behavior mode to UDRD POD slot through POD extender, tune 74 at 1.544 Mbps, invert spectrum if necessary.

Connect serial data and clock out from POD extender to Firebird.

Procedure:

Step	Procedure
1	Verify that Firebird received data matches transmit data (no Errs).
2	Combine NTSC and QPSK signals at UDRD input.
3	Verify that Firebird received data matches transmit data (2.5 E-6 error rate or better).
4	Combine 256QAM and QPSK signals at UDRD input.
5	Verify that Firebird received data matches transmit data (2.5 E-6 error rate or better).

Test Results: FDC Adjacent Channel Characteristics Test

Measurement	Acceptable Result	Results	Comments
NTSC Analog channel relative to FDC HRFAcc.6	Firebird output and input match		_____
256QAM channel relative to FDC HRFAcc.6	Firebird output and input match		_____

PICS Coverage for this Procedure:

PICS Item	Quality
HRFAcc.6	Direct

Optional Procedure used at CableLabs.

Introduction: This test verifies OOB transmission bit rates and the performance of FDC reception in the presence of higher power adjacent channels of various modulation types.

Equipment: UDRD with Sycard signal breakout board, HPNX Test tool , use TTC Firebird 6000A Communications Analyzer with Lab BNC interface (or like component), QAM/QPSK modulator capable of generating PRBS stream, such as Broadcom BCM93133 (or Radyne Comstream QAM256), CableCARD extender with FDC serial out pin leads (AD14 and CBE#1), 2 channel TTL to 75 ohm buffer, NTSC CH 5 source at +15 dBmV, Sencore player with 256QAM IF output, C6U upconverter, CH 5 source at +15 dBmV, Signal Generator, Spectrum analyzer for reference, RF modulator, and RF combiner.

Setup:

Step	Procedure
1.	Setup Firebird: Data: $2^{15} - 1$; Gen Clk: Synth; Timing Mode: Sync; Menu Intf Setup: Lab; Menu Synth Freq: Test these three Bit Rates: 1.544Mbps; Change Signal Gen Freq for each Test. Setup the Firebird Analysis Results: Signal/ Rcv Frequency and Error Bit Errs; Analysis Mode: Continuous.
2.	Setup QAM/QPSK modulator: Data source PRBS $2^{15} - 1$, Change Symbol rates for each test: 0.772Mymbols per second for 1.544Mbp Test. Note: If output is 44 MHz IF only, use RF mixer and RF generator (30MHz, @10 dBm) to generate 74MHz QPSK signal.
3.	Verify QAM/QPSK modulator operational control on front panel display: QAM 4, No FEC, PRBS_15, SYM Fixed 0.772, CH=N/A, a=0.12, IF=44.0, MPEG: N/A, s=NORM, INTLVR:N/A
4.	Measure and pad attenuation of the 44Mhz IF output from QPSK modulator with Spectrum Analyzer to 0 dBmV. Combine 44Mhz IF with 30MHz Signal Generator into mixer for 74MHz signal. Measure and pad attenuation this output signal - 7dBmV.
5.	Connect Fireberd serial Rx data to UDRD Sycard signal break out board pin AD14 and Rx Clock to pin CBE1 using TTL buffer to 75 ohm driver adapter.
6.	Bring up the HPNX software on the given PC, and verify that the PC and HPNX are on the same isolated network.
7.	Under the Device tab, click on the name of the HPNX that you are working with.
8.	Select the CableCARD Behavior mode and click connect. Trace window should show device connecting, connected, initializing and ready. Right click in the Trace window to select SPDU, TPDU and Payload for full vision of all layers.
9.	Click Test to go to Resources. Click Play in CableCARD –Low Level test/setup. In trace window verify device inserted properly with Open_session_request and Open_session_response.
10.	Go to Host Control, click play in “session slot”. Host Control menu shows Session nb (opened). Trace window shows Open Session request/response from Host Control.
11.	From HPNX, open OOB_RX_tune_req menu tab. Enter Frequency 74000 Set Bit Rate same as Sync Frequency of Fireberd. Check Spectrum Inv. depending upon RF Modulator Modulation. (Try one then the other if you are not sure). Click “Send” and verify in trace window that tuning is granted.
12.	Verify the Fireberd tester receiver Locks “Sync” (Green) and “MK, SP” LEDs stay yellow. (FYI) Procedure for Fireberd Setup Ref: Under Analysis Results menu arrow up/down to set left side category to Signal Arrow right/left to set RCV Frequency on display. (RCV Frequency should be Bit Rate sent from HPNX) Setup Fireberd for BER in Analysis Results right side menu by arrow up/down to ERROR; use arrow right/left to either errors, BER or Ave. BER.

13.	Setup a 256QAM output to GI C6U tuned to EIA 5. Combine 256QAM with mixed QPSK signal into an RF combiner for adjacent channel testing. Run through the three sync frequencies defined above changing Bit Rates on Fireberd, HPNX/OOB RX tune req and Symbol Rate of Broadcom modulator.
-----	--

Diagram:

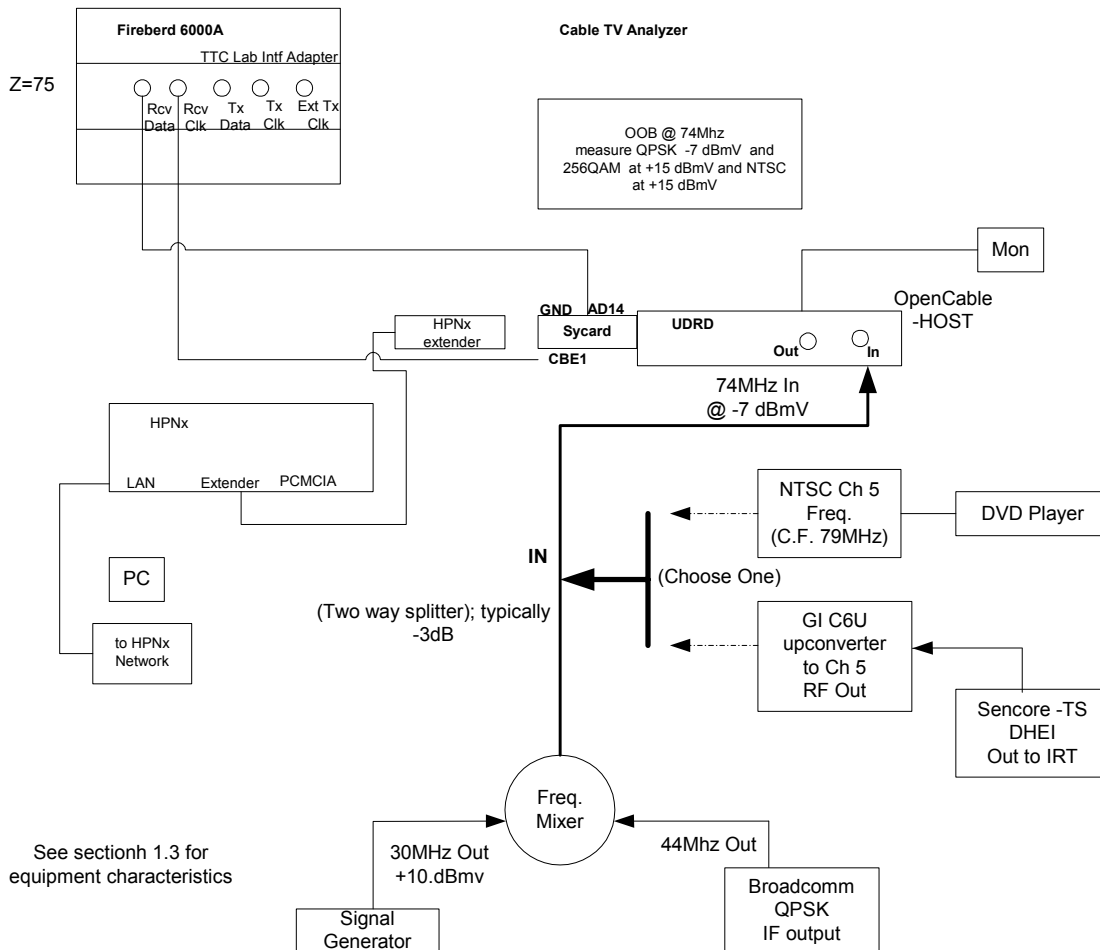

Note: Do all padding after the output of the mixer only.

Procedure:

1. Setup HPNX to transmit the OOB at 74MHz and test defined Bit Rate on the Fireberd BER Tester.

Verify each; Lock Sync on the Tester for the specific Bit Rate used.

Note: If Broadcomm Modular: Symbol Rate needs to be changed to match Bit Rate.

QPSK Symbol Rate is 1/2 Bit Rate.

Output of IF = 0dbmv. (+/- 2dbmv)

2. Then combine NTSC CH. 5 source (Output C.F. 79MHz = (+15dbmv)) to the mixer output signal (74MHz) and re-test for adjacent channel interference. (Reference diagram)

3. Disconnect NTSC CH. 5 source.
4. Then combine QAM channel 5 sources with mixer output and re-test for adjacent channel interference. (Reference diagram)

Step	Test Verification
1	Verify UDRD FDC locked @ 74Mbps and that Firebird received data Sync Locks to Bit Rate: Sync Lock Threshold table: Sync RCV Frequency 1.544Mbps (no worse than BER 2.5x E-06).
2	Test RF QPSK output with Bit Rates of 1.544Mbps. Run Sync lock test and verify BER error rates as defined above (step 1).
3	Combine 256QAM with QPSK signals to UDRD input. Verify that this adjacent channel does not have direct effect on FDC and that BER range is acceptable.
4	Verify that Firebird received data Sync Locks. Run Sync lock test and verify Bit error ranges is acceptable for the bit rate tested.
5	Combine NTSC and QPSK signals to UDRD input. Verify adjacent channel does not have direct effect on FDC and BER range is acceptable.

Test Results: FDC Adjacent Channel Characteristics Test

Measurement	Acceptable Result	Results	Comments
NTSC Analog channel relative to FDC HRFAcc.6	Firebird output and input match		_____
256QAM channel relative to FDC HRFAcc.6	Firebird output and input match		_____

PICS Coverage for this Procedure:

PICS Item	Quality
HRFAcc.6	Direct

2.2.26 FDC Amplitude Parametric Test

Introduction: The forward data channel (FDC) is the out-of-band communication channel from the headend to the UDRD. The modulation scheme is QPSK, with data rate of 1.544Mbps. The frequency range is from 70MHz to 130MHz with step size of 250KHz.

Equipment: UDRD, TTC Firebird 6000A communications analyzer, RF Networks 5450 QPSK modem, HPNX POD emulator, POD extender card, Spectrum analyzer, two-way splitter, and variable attenuator.

NOTE: CableLabs has an alternate equipment setup using a modulator with an internal PRBS generator (Broadcom BCM93133).

NOTE: Test to be performed at 75.25 MHz, 1.544 Mbps, +/- 15 dBmV

Setup: Settings for Firebird: Data: 2¹⁵-1; Gen Clk: Synth; Timing Mode: Sync; Menu Intf Setup: Lab; Menu Synth Freq: 1.544; Signal Gen Freq 1544000; Signal Rcv freq 1544000 or Error Bit Errs; Analysis Mode: Continuous
Connect Firebird clock and data lines to QPSK modem at -7 dBmV, 75.25 MHz, 1.544 Mbps.
Connect modem to UDRD cable input.
Connect HPNX in POD behavior mode to UDRD POD slot through POD extender, tune 75.25 at 1.544 Mbps, invert spectrum if necessary.

Connect serial data and clock out from POD extender to Firebird.

Procedure:

1. Adjust the FDC carrier level to -15dBmV (lowest limit).
2. Verify that Firebird received data matches transmit data (2.5 E-6 error rate or better).
3. Next adjust the carrier level to its maximum level (+15dBmV).
4. Verify that Firebird received data matches transmit data (2.5 E-6 error rate or better).

Test Results: FDC Channel Parametric Test

Measurement	Acceptable Result	Results	Comments
RF Input level range, -15 to +15 dBmV HFDCrf.8	The UDRD can still receive out-of-band data at -15dBmV and +15dBmV		_____

PICS Coverage for this Procedure

PICS Item	Quality
HFDCrf.8	Direct

2.2.27 FDC tuning range and bit rate test

Introduction: This test verifies tuning range for all three OOB transmission bit rates and verifies reception with channel impairment.

Equipment: UDRD, TTC Fireberd 6000A communications analyzer, RF Networks 5450 QPSK Modem, HPNX emulator, POD extender with FDC serial out (clock on pin CBE1, data on pin AD14), HP11759D Ghost Simulator.

NOTE: CableLabs has an alternate equipment setup using a modulator with an internal PRBS generator (Broadcom BCM93133).

Setup: Settings for Fireberd: Data: 2¹⁵-1; Gen Clk: Synth; Timing Mode: Sync; Menu Intf Setup: Lab; Menu Synth Freq: 1.544; Signal Gen Freq 1544000; Signal Rcv freq 1544000 or Error Bit Errs; Analysis Mode: Continuous

Connect Fireberd clock and data lines to QPSK modem at -7 dBmV, 75.25 MHz, 1.544 Mbps.

Connect modem to UDRD cable input.

Connect HPNX in POD behavior mode to UDRD POD slot through POD extender, tune 75.25 at 1.544 Mbps, invert spectrum if necessary.

Connect serial data and clock out from POD extender to Fireberd., Ghost Simulator RF freq: 73 MHz; LO freq: 67 MHz

Procedure:

1. Set up the OOB mod at 75.25MHz with bit rate of 1.544 Mbps.
2. Connect QPSK source through Ghost Simulator.
3. Set Ghost generator primary path for static phase, 0dB attenuation, 0 phase, 0 delay
4. Set the Ghost generator secondary paths 2 through 6 to OFF. Re-Calibrate QPSK source to -7 dBmV, @ input to UDRD and tune OOB tuner.
 - a. From HPNX, open OOB_RX_tune_req menu tab.
 - b. Enter Frequency 752500
 - c. Set Bit Rate same as Synth Frequency of Fireberd.
 - d. Check Spectrum Inv. depending upon RF Modulator Modulation. (Try one then the other if you are not sure).
 - e. Click "Send" and verify in trace window that tuning is granted.
5. Verify that Fireberd received data matches transmit data (2.5 E-6 error rate or better).
6. Set up the OOB mod to 104.2 MHz at bit rate of 2.048Mbps.
NOTE: RF Networks modulators have fixed bandwidth filters. Changing data rates means changing modulators.

7. Re-Calibrate QPSK source to -7 dBmV, @ input to UDRD and tune OOB tuner.
 - a. From HPNX, open OOB_RX_tune_req menu tab.
 - b. Enter Frequency 1042000
 - c. Set Bit Rate same as Synth Frequency of Fireberd.
 - d. Check Spectrum Inv. depending upon RF Modulator Modulation. (Try one then the other if you are not sure).
 - e. Click "Send" and verify in trace window that tuning is granted.
8. Verify that Fireberd received data matches transmit data (2.5 E-6 error rate or better).
9. Set up the OOB mod to 125MHz with a bit rate of 3.088Mbps.
NOTE: RF Networks modulators have fixed bandwidth filters. Changing data rates means changing modulators.
10. Re-Calibrate QPSK source to -7 dBmV, @ input to UDRD and tune OOB tuner.
 - a. From HPNX, open OOB_RX_tune_req menu tab.
 - b. Enter Frequency 1250000
 - c. Set Bit Rate same as Synth Frequency of Fireberd.
 - d. Check Spectrum Inv. depending upon RF Modulator Modulation. (Try one then the other if you are not sure).
 - e. Click "Send" and verify in trace window that tuning is granted.
11. Change Ghost Simulator RF freq: 122.75 MHz; LO freq: 116.75 MHz
12. Set the Ghost generator secondary path to Phase, -13 dB @ 0.5 uSec, 0 degrees referenced to RF channel center freq.
13. Verify that Fireberd received data matches transmit data (2.5 E-6 error rate or better).

Test Results: FDC tuning range and bit rate test

Measurement	Acceptable Result	Results	Comments
Tune FDC low freq, low bit rate	Fireberd output and input match		_____
Tune FDC mid freq, mid bit rate	Fireberd output and input match		
Tune FDC high freq, high bit rate	Fireberd output and input match		
Receive FDC data	Fireberd output and input match		

PICS Coverage for this Procedure

PICS Item	Quality
FDCP.2	Direct

PICS Item	Quality
FDCP.3	Direct
HFDCrf.5a	Direct
HFDCrf.12	Direct
HFDCrf.24	Indirect
HFDCrf.27	Indirect
HFDCrf.27A	Indirect
HFDCrf.32	Indirect
HFDCrf.33	Indirect
HFDCrf.7	Indirect

2.2.28 Digital Video Compression Test

Equipment: Host (UDRD), Digital Stream Player (Analyzer), Cable SD Bitstreams Version 1.1, (Sarnoff Part# SCB-CABSD v.1.1), Sarnoff HD OpenCable Test Streams (SCB-CABHD-VTT), and QAM Modulator

Setup: Connect Host Device (UDRD) in one of the two following ways:

For testing Sarnoff SD OpenCable Test Streams:

1. Connect the Stream Player (containing the Sarnoff test stream) to a QAM Modulator. Set QAM modulator to 256 QAM. Bring the stream player and QAM Modulator up to a stable operating state.
2. Tune the QAM Modulator and the UDRD to the same major channel. Ensure all programs within the selected stream frequency are “clear” channels, (not encrypted).
3. Program the QAM Modulator in the appropriate mode, to “pass through” the desired digital test stream from the Stream Player.
4. Connect the RF output of the QAM Modulator to the RF input of the UDRD. Ensure output levels are set and attenuator pads added for the desired RF level into the UDRD, (to -7dBmV , mid channel). Connect the RF output of the UDRD (or audio/video) to a television monitor, if necessary.
5. Tune the UDRD to minor channel one.

For testing Sarnoff HD OpenCable Test Streams:

1. Connect the Stream Player (containing the Sarnoff test stream) to a QAM Modulator. Set QAM modulator to 64 QAM. Bring the stream player and QAM Modulator up to a stable operating state.
2. Tune the QAM Modulator and the UDRD to the same major channel. Ensure all programs within the selected stream frequency are “clear” channels, (not encrypted).
3. Program the QAM Modulator in the appropriate mode, to “pass through” the desired digital test stream from the Stream Player.
4. Connect the RF output of the QAM Modulator to the RF input of the UDRD. Ensure output levels are set and attenuator pads added for the desired RF level into the UDRD, (to -7dBmV , mid channel). Connect the RF output of the UDRD (or audio/video) to a television monitor, if necessary.
5. Tune the UDRD to minor channel one.

Testing:

This test will operate according to the test grid listed in below table of this document. The grid is divided into test "segment". Each segment will have start and stop packet counts, (or times). The Stream Player may be placed in the "loop mode", allowing the UDRD sufficient time to acquire the test stream signal, and display to the television monitor. Play each segment of the test noting the output display of the television monitor for each segment.

Each test begins with a one-second-title screen describing the format under test. The title screen contains two moving elements to indicate that the UDRD is functioning: An orange block moving from left to right in a small black box and light-gray bars moving from left to right on the top and bottom of the screen.

The title screen is followed by an approximately three-second test sequence containing several moving elements: Two green vertical bars moving smoothly from left to right, two yellow horizontal bars moving from top to bottom, a large black region that fills with white blocks, and a small box in each corner of the screen which changes slowly from black to white.

NOTE: Each test repeats three times, making one test segment. Please ensure that you are the beginning of the stream before beginning this test. Dead time at the end of the loop may appear as video freezes or blank screens, due to the stream player 'rewinding' to the beginning.

Digital Video Compression Test Table (Sarnoff SD OpenCable Formats)

Program	Test Segment	H-size	V-size	Aspect	Prog	Fr-rate	Start Packet	Stop Packet	Pass/Fail Comments
1 PID 0x31 Ch 22-1	1	720	480	3	1	1			
	2	720	480	2	1	1			
	3	704	480	3	1	1			
	4	704	480	2	1	1			
	5	640	480	1	1	1			
	6	640	480	2	1	1			
	7	544	480	2	1	1			
	8	528	480	2	1	1			
	9	352	480	2	1	1			
2 PID 0x41 Ch 22-2	1	720	480	3	1	2			
	2	720	480	2	1	2			
	3	704	480	3	1	2			
	4	704	480	2	1	2			
	5	640	480	1	1	2			
	6	640	480	2	1	2			
3 PID 0x51 Ch 22-3	1	720	480	3	1	4			
	2	720	480	3	0	4			
	3	720	480	2	1	4			
	4	720	480	2	0	4			
	5	704	480	3	1	4			
	6	704	480	3	0	4			
	7	704	480	2	1	4			
	8	704	480	2	0	4			
4 PID 0x61 Ch 22-4	1	640	480	1	1	4			
	2	640	480	1	0	4			
	3	640	480	2	1	4			
	4	640	480	2	0	4			

	5	544	480	2	0	4			
	6	528	480	2	0	4			
	7	352	480	2	0	4			
5 PID 0x71 Ch 22-5	1	720	480	3	1	5			
	2	720	480	3	0	5			
	3	720	480	2	1	5			
	4	720	480	2	0	5			
	5	704	480	3	1	5			
	6	704	480	3	0	5			
	7	704	480	2	1	5			
	8	704	480	2	0	5			
6 PID 0x81 Ch 22-6	1	640	480	3	1	5			
	2	640	480	3	0	5			
	3	640	480	2	1	5			
	4	640	480	2	0	5			

Digital Video Compression Test Table (Sarnoff HD OpenCable Formats)

Program	Test Segment	H-size	V-size	Aspect	Prog	Fr-rate	Start Packet	Stop Packet	Pass/Fail Comments
	1	1920	1080	1	1	1			
	2	1920	1080	1	1	2			
	3	1920	1080	1	1	4			
	4	1920	1080	1	1	5			
	5	1920	1080	3	1	1			
	6	1920	1080	3	1	2			
	7	1920	1080	3	1	4			
	8	1920	1080	3	1	5			
	9	1920	1080	1	0	4			
	10	1920	1080	1	0	5			
	11	1920	1080	3	0	4			
	12	1920	1080	3	0	5			
	13	1440	1080	3	1	1			
	14	1440	1080	3	1	2			
	15	1440	1080	3	1	4			
	16	1440	1080	3	1	5			
	17	1440	1080	3	0	4			
	18	1440	1080	3	0	5			
	19	1280	720	1	1	1			
	20	1280	720	1	1	2			
	21	1280	720	1	1	4			
	22	1280	720	1	1	5			
	23	1280	720	1	1	7			
	24	1280	720	1	1	8			
	25	1280	720	3	1	1			
	26	1280	720	3	1	2			
	27	1280	720	3	1	4			
	28	1280	720	3	1	5			
	29	1280	720	3	1	7			
	30	1280	720	3	1	8			

	31	704	480	2	1	7			
	32	704	480	2	1	8			
	33	704	480	3	1	7			
	34	704	480	3	1	8			
	35	720	480	2	1	7			
	36	720	480	2	1	8			
	37	720	480	3	1	7			
	38	720	480	3	1	8			
	39	640	480	1	1	7			
	40	640	480	1	1	8			
	41	640	480	2	1	7			
	42	640	480	2	1	8			

Legend for MPEG-2 coded values in Table 3	
Aspect_ratio_information	1 = square samples 2 = 4:3 display aspect ratio 3 = 16:9 display aspect ratio
Frame_rate_code	1 = 23.976 Hz 2 = 24 Hz 4 = 29.97 Hz 5 = 30 Hz 7 = 59.94 Hz 8 = 60 Hz
Progressive_sequence	0 = interlaced scan 1 = progressive scan

Test Results: Digital Video Compression Test

Measurement	Acceptable Result	Results	Comments
QAM Modulator set for 256 QAM for SD test formats and 64QAM for HD test formats. Display output from the UDRD on a television monitor, for each Test Segment. HNETdig_vid.2, HNETdig_vid.3, HNETdig_vid.7, HNETdig_vid.8, HNETdig_vid.10, HNETdig_vid.11, HNETdig_vid.12, HNETdig_vid.13, HNETdig_vid.14, HNETdig_vid.15, HNETdig_vid.16, HNETdig_vid.17, HNETdig_vid.18, HNETdig_vid.19,	The blocks should smoothly fill in the black region and the colored bars should move cleanly across the screen. If black gaps are left in the center box or stationary colored bars are left behind the moving bars, pictures have most likely been skipped in decoding, failing the test. Each test segment must pass, any failure of a test segment, fails this test item.		

HOST PICS Coverage for this Procedure

PICS Item	Quality
HNETdig_vid.2	Direct
HNETdig_vid.3	Indirect
HNETdig_vid.7	Direct
HNETdig_vid.8	Direct
HNETdig_vid.10	Direct
HNETdig_vid.11	Direct
HNETdig_vid.12	Direct
HNETdig_vid.13	Direct
HNETdig_vid.14	Direct

PICS Item	Quality
HNETdig_vid.15	Direct
HNETdig_vid.16	Direct
HNETdig_vid.17	Direct
HNETdig_vid.18	Direct
HNETdig_vid.19	Direct

Table Compression Format Constraints

vertical_size_ value	horizontal_size_ value	aspect_ratio_ information	frame_rate_ code	progressive_ sequence
1080	1920	1,3	1,2,4,5	1
1080	1920	1,3	4,5	0
1080	1440	3	1,2,4,5	1
1080	1440	3	4,5	0
720	1280	1,3	1,2,4,5,7,8	1
480	720	2,3	1,2,4,5,7,8	1
480	720	2,3	4,5	0
480	704	2,3	1,2,4,5,7,8	1
480	704	2,3	4,5	0
480	640	1,2	1,2,4,5,7,8	1
480	640	1,2	4,5	0
480	544	2	1	1
480	544	2	4	0
480	528	2	1	1
480	528	2	4	0
480	352	2	1	1
480	352	2	4	0

2.2.29 Digital Closed Caption

This test verifies the UDRD handles various Closed Caption options.

Introduction: This test utilizes a closed caption test file that provides a full variety of closed caption formats based on CEA/EIA-608-B, CEA/EIA-708-B standards, in both encapsulation formats. It will test the UDRD capabilities to receive and display the closed captioning.

Equipment: UDRD, QAM modulator, stream play out device w/ the below Closed Caption Test Files:

Note: The attached file describes the caption contents of these files.



"test
Text-11Nov2003.txt"

Filename	Description
"SCTE20_only.mpg"	Contains only SCTE20 user data extensions, with NTSC captioning. The caption at the beginning of the stream reads: 608 CC
"SCTE20&SCTE21_NTSC&DTVCC.mpg"	Contains SCTE20 user data extensions with NTSC captioning, and SCTE21 user data extensions with both NTSC and DTVCC in them. The caption at the beginning of the stream reads: 608 CC 608B CC 708B CC
"SCTE21_NTSC&DTVCC.mpg"	Contains only SCTE21 user data extensions with both NTSC and DTVCC in them. The caption at the beginning of the stream reads: 608B CC 708B CC

There are 3 test streams provided that have different locations for private user data mixed in with both types of standard user data. All streams have both SCTE 20 and SCTE 21 data and other user data field(s).

PowerVu 4-7-3.ts	Private User Data first
PowerVu 7-4-3.ts	Private User Data second
PowerVu 7-3-4.ts	Private User Data third

Files in this section use the same content.

- Video test pattern – 75% bars
- AC3 Audio 500 Hz Tone
- CC Test Pattern is the string “Scientific Atlanta (CC F1)” repeated constantly

Setup: Connect the stream play out device to the QAM modulator. Connect the feed from modulator into the RF input to the UDRD (to –7dBmv, mid channel). Connect the output of the UDRD to a TV (If necessary). Tune the UDRD to the same channel as the modulator. Verify the stream is present.

Closed Captioning Procedure:

The Stream Player may be place in the “loop mode”, allowing the UDRD sufficient time to acquire the test stream signal, and display correctly. Note the output display of the UDRD.

Verify that for minor channel 1 and for minor channel 2 that recognizable English captioning is displayable on the UDRD. Note that during ‘looping’ video may appear frozen, etc. Repeat for each of the six test streams.

For UDRD's with NTSC analog video output (HSTDCC.4): Tune the UDRD to the same channel as the modulator, using the “SCTE21_NTSC&DTVCC.mpg” test stream confirm the presence of the stream on the UDRD. Connect the NTSC analog output of the UDRD to an NTSC (analog) input of an analog TV with verified captioning capability. Power on the analog TV and select the proper input coming from the UDRD from the menu on the analog TV. Verify closed captioning is enabled on the analog TV and is properly displayed.

Test Results: Closed Caption

Measurement	Acceptable Result	Results	Comments
Check Closed caption display for each segment of the test	Closed caption displays correctly. Enter result in Table 1		
On any NTSC analog output, make sure that Line 21 contains the encoded captioning [HNIACC.1]	Closed caption carried correctly. Enter result in Table 1 This test is not applicable if the UDRD does not have an NTSC analog output.		

PICS Item	Quality
HSTDCC.1	Direct
HSTDCC.2	Direct
HSTDCC.3	Direct
HSTDCC.3a	Direct
HSTDCC.4	Direct
HSTDCC.68	Direct
HNIACC.1	Direct
Hnirate.4	Indirect

3 EQUIPMENT CONFIGURATION

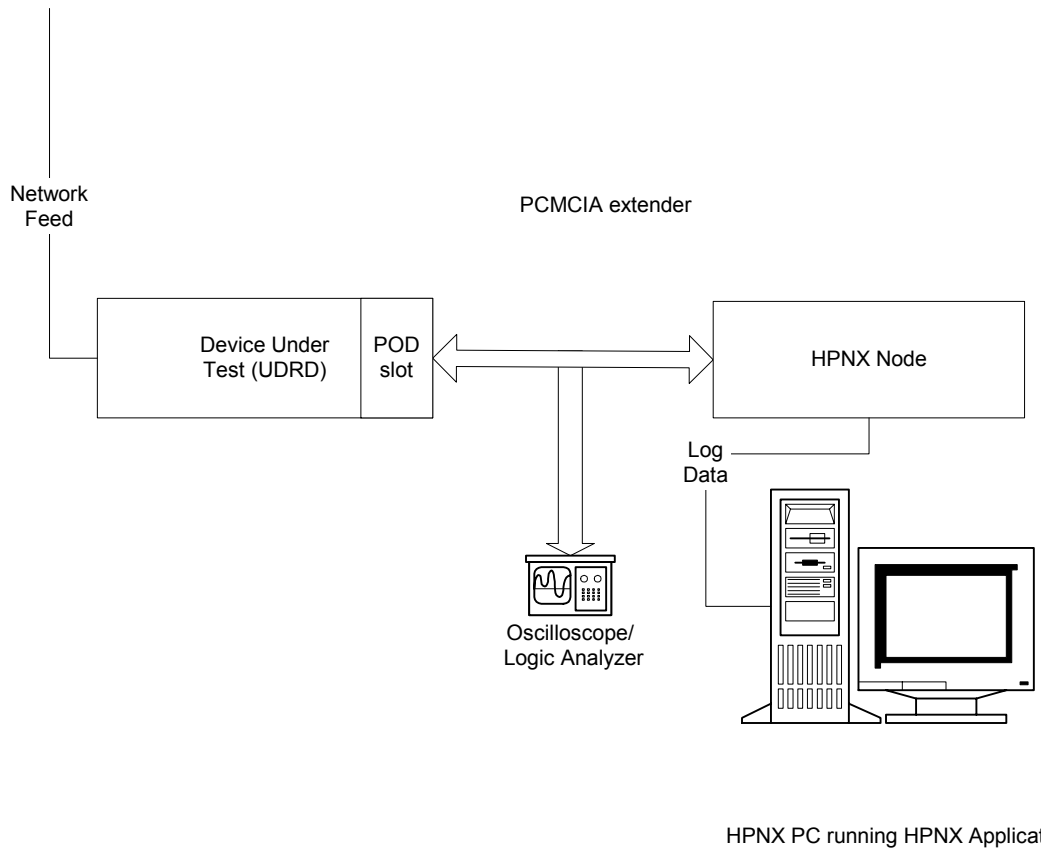

Figure 1: HPNX test configuration for Host ATP

Interoperability Tests

4 SCIENTIFIC ATLANTA, MOTOROLA & HARMONIC

4.1 CORE Interoperability Tests

All tests in this section are to be performed with the assumption that the CableCARD being used will match the headend network. Each host must be tested against all available qualified CableCARD's (Motorola, SA, Harmonic, etc.) for this interoperability test procedure.

1. Verify that the CableCARD and host combination present a MMI message screen that asks the user to call in and register the CableCARD and Host ID's. (Note: This will only happen on initial mating of the CableCARD and Host).

Headend	Results	Comments
Motorola		
Scientific Atlanta		
Harmonic		

2. Verify that the CableCARD and host combination display an MMI message screen with the CableCARD ID and Host ID as part of the MMI display. Exit the MMI screen and following manufacture instructions bring up the MMI screen through the application information resource selection screen.

Headend	Results	Comments
Motorola		
Scientific Atlanta		
Harmonic		

3. Physically unplug input power from host/CableCARD combination. Wait 10 seconds and reapply input power, verify that the CableCARD, host combination, successfully re-

initialize and return to the state left in step 1, without requiring a re-initialization from the CA system.

Headend	Results	Comments
Motorola Scientific Atlanta Harmonic		

- Confirm that the CableCARD, host combination can be turned on and off at least 5 times and successfully recover after each power cycle. A successful recovery is defined by the CableCARD and host combination not requiring a CableCARD re-initialization.

Headend	Results	Comments
Motorola Scientific Atlanta Harmonic		

- Verify CableCARD; host combination has basic user interface function of Channel up/down. Changing channels up then down on the host and confirming that they are displayed according to the channel map on the CA system.

Headend	Results	Comments
Motorola Scientific Atlanta Harmonic		

- Verify the ability of CableCARD, host combination to tune clear analog channels. Reference CA system for channel map information and tune to an analog service, verify audio and video on UDRD.

Headend	Results	Comments
Motorola Scientific Atlanta Harmonic		

7. Verify the ability of CableCARD; host combination to tune unencrypted QAM64. Reference CA system for channel map information and tune to a QAM64 multiplex, verify audio and video on UDRD.

Headend	Results	Comments
Motorola Scientific Atlanta Harmonic		

8. Verify the ability of CableCARD; host combination to tune unencrypted QAM256. Reference CA system for channel map information and tune to a QAM256 multiplex, verify audio and video on UDRD.

Headend	Results	Comments
Motorola Scientific Atlanta Harmonic		

9. Authorize the CableCARD, host combination for an encrypted digital service through the CA System. Verify the UDRD can display an encrypted digital service.

Headend	Results	Comments
Motorola Scientific Atlanta Harmonic		

10. De-authorize a CableCARD host combination for an encrypted digital service through the CA system. Verify the UDRD cannot display any encrypted digital service.

Headend	Results	Comments
Motorola Scientific Atlanta Harmonic		

11. Tune the CableCARD, host combination to an analog service. Send an EAS message from the CA system/head-end and verify EAS message is received. This will be in the form of a FORCE TUNE.

Headend	Results	Comments
Motorola		
Scientific Atlanta		
Harmonic		

12. Tune the CableCARD, host combination to a digital service. Send an EAS message from the CA system/head-end and verify EAS message is received. This will be in the form of a FORCE TUNE.

Headend	Results	Comments
Motorola		
Scientific Atlanta		
Harmonic		

13. Verify CableCARD and host ability to re-acquire QAM64 FAT channel. Tune CableCARD and host combination, to a QAM64 multiplex. Physically remove F-connector from the back of the host. Wait 10 seconds and reconnect. Verify that the CableCARD and host combination can re-acquire QAM64 FAT channel and display audio and video on UDRD (May require a channel change to re-acquire or other user intervention).

Headend	Results	Comments
Motorola		
Scientific Atlanta		
Harmonic		

14. Verify CableCARD and host ability to re-acquire QAM256 FAT channel. Tune CableCARD and host combination, to a QAM256 multiplex. Physically remove F-connector from the back of the host. Wait 10 seconds and reconnect. Verify that the CableCARD and host combination can re-acquire QAM256 FAT channel and display audio and video on UDRD (May require a channel change to re-acquire or other user intervention).

Headend	Results	Comments
Motorola Scientific Atlanta Harmonic		

15. Using the Scientific Atlanta CableCARD verify the ability for the CableCard to do a firmware upgrade.

Headend	Results	Comments
Scientific Atlanta		
